

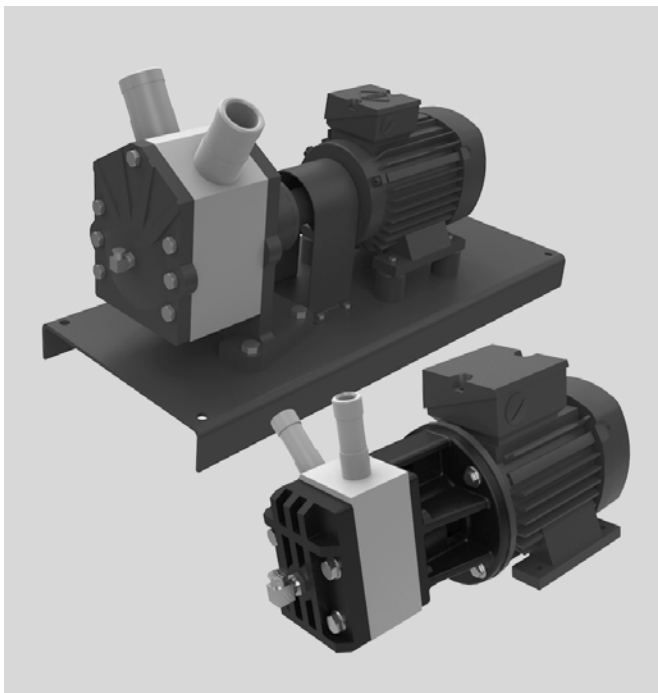

# ASV Eccentric Pumps

## Type F and Type L

»self-priming - dry running capable«



Technical data	Type F	Type L
Flow rate Q	up to 1,8 m <sup>3</sup> /h	up to 5,2 m <sup>3</sup> /h
Head H	up to 25 m	up to 25 m
Suction height H	max. 5 m	max. 5 m
Materials limits of use	PVC-U up to 50°C	
housing	PE-HD up to 60°C	
	PP up to 80°C	
	PVDF, PTFE up to 100°C	
liner	EPDM, FPM up to 100°C	
Pressure socket	d 21 ... d 27	d 21 ... d 52
Drive capacity	up to 0,37 kW	up to 1,1 kW
Explosion protection (ATEX)	on request	
		

### Design

- The ASV eccentric thermoplastic pump series F and L are dry running capable, self-priming displacement pumps of horizontal design.

### Sizes

- F4, F9, F12, F16, F30
- L4, L9, L12, L16, L30, L70, L100

### Technical design

- Type »F« as a flange pump with a directly coupled drive motor or as type »FF« with a frequency changer, in the sizes F4 ... F30
- Type »L« or »LF« with a frequency changer, as a foot mounted pump in the sizes L4 ... L100, mounted on the base plate with drive motor, elastic coupling and contact protection (DIN 294/DIN 31 001).
- Thermoplastic pump housing
- Connections for industrial hoses
- Mechanical seal
- Max. suction height: 5m WC

### Drive

- Type series F and L:  
with a constant rotational speed
- Type series FF and LF:  
with variable rotational speed, frequency regulated for requirement based controlled delivery rates, low energy consumption and optimum efficiency

### Accessories:

- ASV pump monitor
- Vibration and pulsation damper
- Suction basket
- Frequency control

### Application

- Chemical plants
- Water treatment
- Galvanotechnics
- Environmental technology
- Processing technology

### Utilisation

- For transportation of neutral, aggressive or abrasive fluids provided that the components coming into contact with the medium are resistant at the operating temperature according to the ASV resistance guide.

### Fluid density/Fluid viscosity

- 1,0 kg/dm<sup>3</sup> up to 800 mPas
- 1,3 kg/dm<sup>3</sup> up to 860 mPas
- 1,6 kg/dm<sup>3</sup> up to 920 mPas

### Examinations

- DIN EN ISO 9906

### Suction

- The pump is self-priming when prior start up the pump the housing is filled with fluid.

### Drive acc. IEC

- Design: IM B 34/35, IM B 3
- Voltage: 230 V AC (1 Ph) or 230/400 V AC (3 Ph)
- Protection type IP 54/55
- Rotational speed refer characteristic curves

### Shaft

- Stainless steel (1.4104)

### Screws

- Stainless steel (1.4301)

### Connections

For pump sockets refer to the dimension tables

- A - Hose, standard length 1.0 m, with two stainless steel hose clips
- B -Hose, standard length 1.0 m, with two PVC flanges acc. DIN 2501

### Construction

- The thermoplastic pump housing accommodates the liner which is secured, liquid sealed, between the housing and the cover plate, motor lantern or pillow block; the web of the liner separates suction and pressure space. A seal between the enclosed pumping liquid and the atmosphere is not required. The pump does without seals, is almost leak free and thus particularly environmentally sound!
- The rotor turns in roller bearings on a cam arranged on the centred drive shaft. An oil film is formed between the rotor and liner. A simple axial face seal separates this film from the large, regreasable roller bearings.

### Presentation of the working sequence

suction section

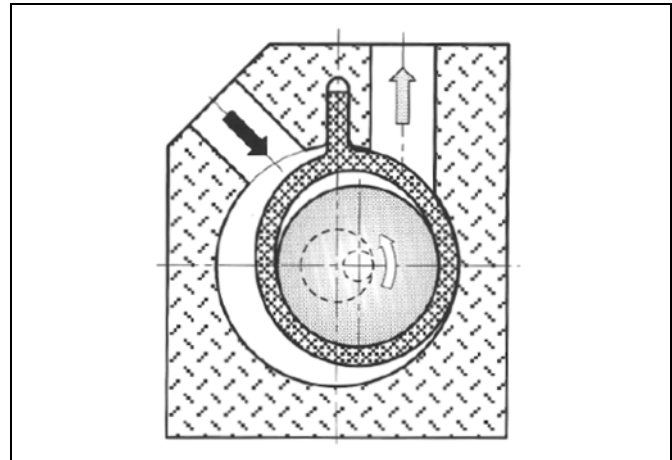

pressure section

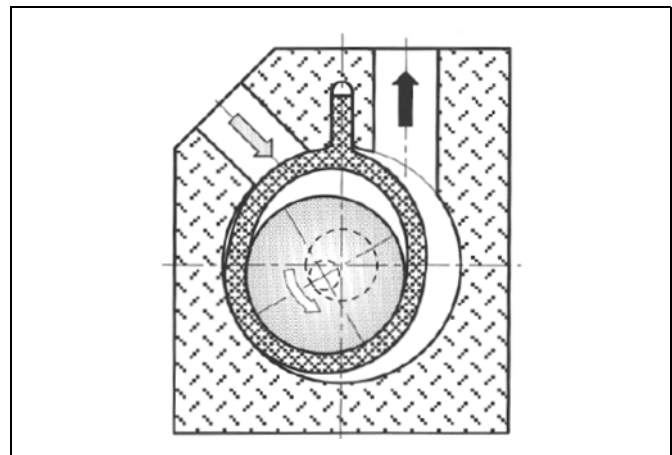

Eccentric pump with drive motor and integrated micro-frequency changer for infinite delivery flow control.

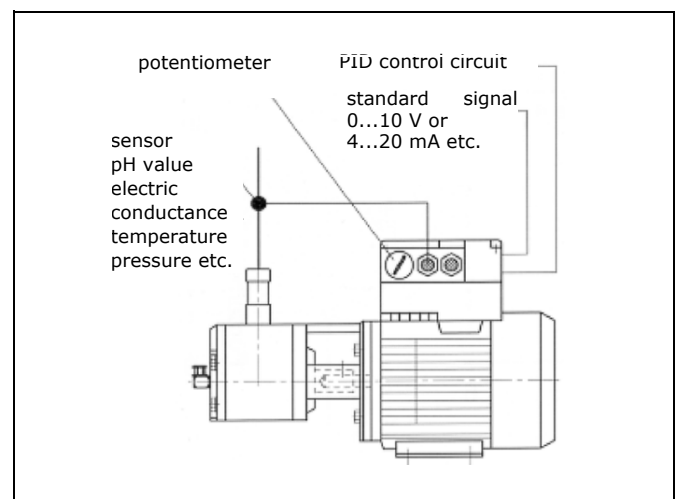

The designs FF and LF with integrated micro-frequency changer permit a rotational speed control of approx. 400 ... 1500 rpm, with larger pumps up to 1000 rpm. The rotational speed can be infinitely set on the potentiometer or fully automatically regulated in the PID control circuit via the standard signal (0... 10 V, 4 ... 20 mA etc.).

### Perm. ambient conditions

- Temperature -20 ... + 40°C
- Humidity up to max. 95%

### Painting

- Several coatings with an acid-proof paint protect all metal parts not made of special steel against corrosion.

### Operating conditions

- Refer to the characteristic curve for the delivery height H to assess the dependence upon the delivery flow Q.
- The standard characteristic curves are determined with water (at RT » 20 °C) in supply operation (suction height  $H_s \geq 0$  m) and with a EPDM liner.
- The delivery flow or the characteristic curves vary slightly if other liner materials are used and, as is normal for rotating displacement pump, are influenced by:
  - Suction heights  $H_s > 2$  m,
  - Medium properties such as temperature, density, viscosity, air/gas share in delivery media etc.
  - Operating mode, i.e. constant or discontinuous intermittent operation.
- Eccentric pumps deliver liquids, even with gas/air inclusions and, once filled with the media, are self priming without additional equipment.
- Due to the venting of medium and longer suction lines the delivered liquid, i.e. the delivery flow Q, drops at a suction height  $H_s > 2.0$  m depending upon the operating circumstances.
- Eccentric pumps are displacement machines. Never operate the pumps when the pressure valves are closed.
- Eccentric pumps require little maintenance and offer a high degree of operational reliability. If, for example, the liner should become worn after a longer operating time, it can be changed easily and quickly without special tools.

### Pump selection

- The correct pump selection is only possible if all medium properties and details of the plant concerned (installation height, pipeline routing, fittings etc.) are known. Please contact us for the »ASV Pump Questionnaire«.
- The pump materials are selected in accordance with the precise chemical composition of your medium and its temperature. Please note that the selection of the pump material is pressure and temperature dependent. Refer the »ASV resistance list«.
- We strongly recommend that you consult our qualified ASV engineers for the following applications:
  - Delivery of viscous or pasty media.
  - Delivery of abrasive liquids.
  - Intended operating rotational speeds in the lower range at approx. 400 rpm and in the upper range of approx. 1500 (1000) rpm.
  - For suction operation with suction heights of  $H_s \geq 2...5$  m as well as all questions concerning suction times, system venting etc.

### Pump accessories

- Flexible hose lines of  $\geq 1.0$  m length can be con-

nected to the pump sockets.

- Vented vibration or pulsation dampers are required for a smooth, low vibration pump operation for delivery heights above approx. 15 m.
- We recommend the fitting of a suction basket to protect the pump from the ingress of coarse soiling conveyed with the medium.

### Sectional drawing type F

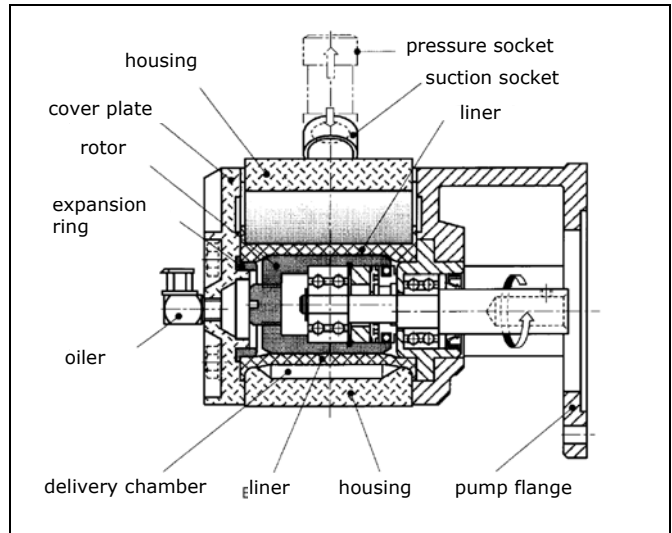

### Sectional drawing type L

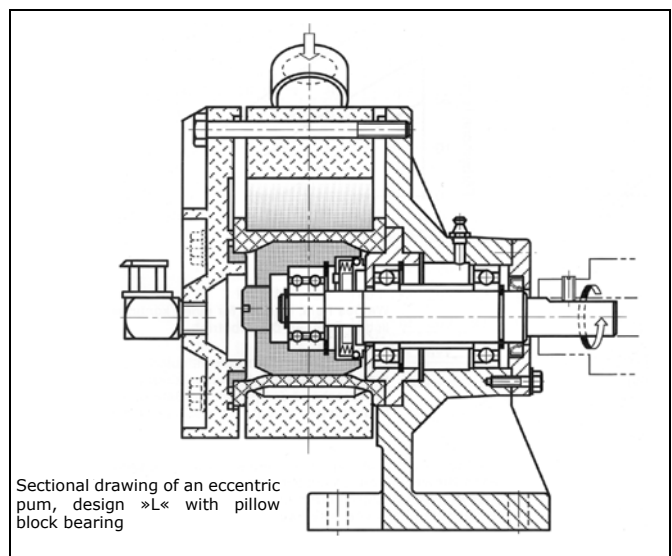

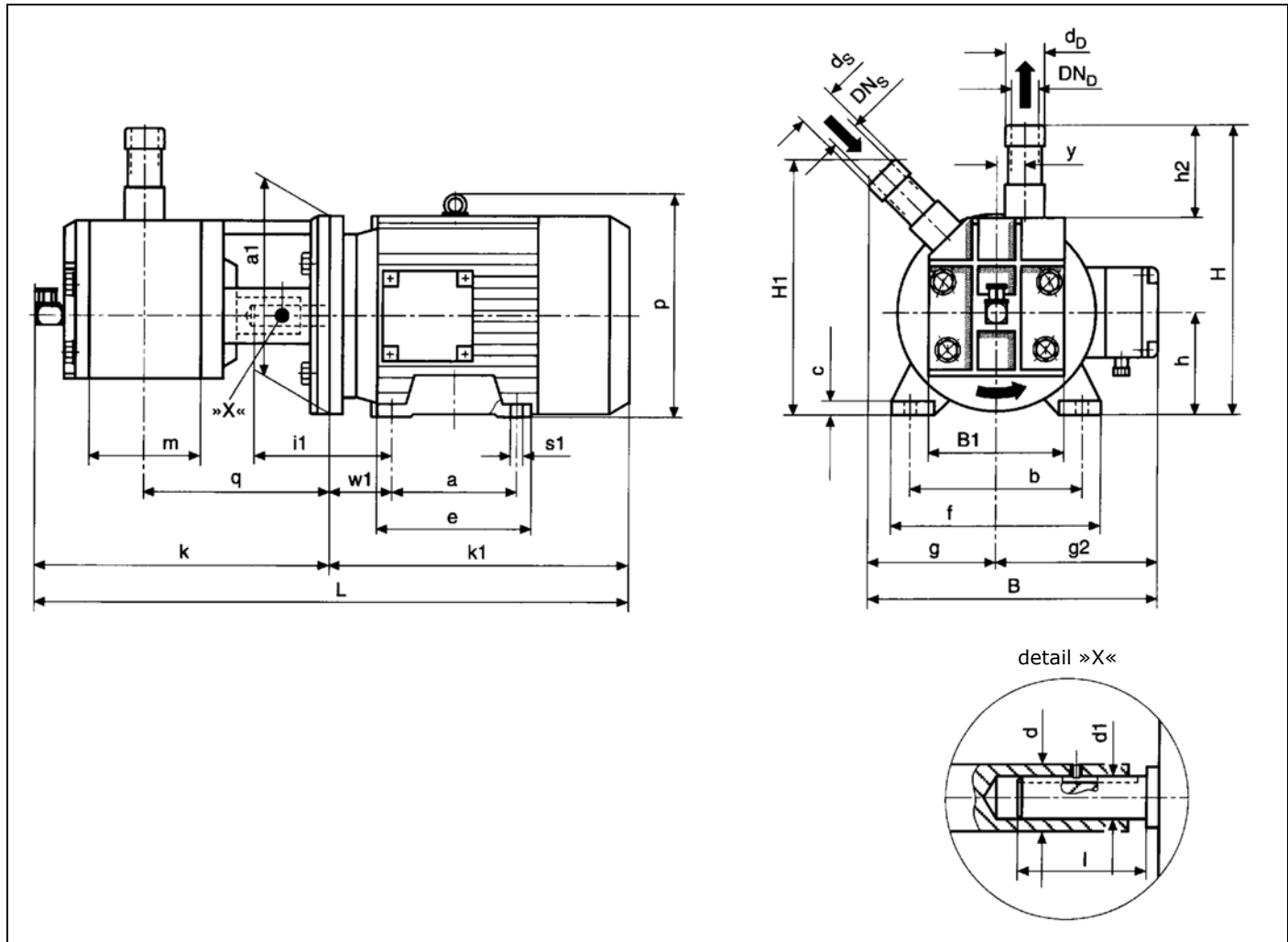
**Dimensions: type F**

type	suction side		pressure side		$P_N$	kW	$n_n$	IEC	design	weight <sup>1)</sup>
	DN <sub>s</sub>	ds	DN <sub>d</sub>	dd						
F 4	14	21	14	21	0,25	1450	71	B34	8,3	
F 9	14	21	14	21	0,25	1450	71	B34	8,3	
F 12	14	21	14	21	0,25	1450	71	B34	8,3	
F 16	19	27	19	27	0,25	1450	71	B34	8,3	
F 30	24	34	19	27	0,37	1450	71	B34	8,3	

1) pump with motor

type	a	a1	b	B	B1	c	d	d1	e	f	g	g2	h	h2	H	H1
F 4	90	140	112	200	92	9	22	14	115	138	85	115	71	60	200	171
F 9	90	140	112	200	92	9	22	14	115	138	85	115	71	60	200	171
F 12	90	140	112	200	92	9	22	14	115	138	85	115	71	60	200	171
F 16	90	140	112	200	92	9	22	14	115	138	85	115	71	60	200	171
F 30	90	140	112	200	92	9	22	14	115	138	85	115	71	60	200	171

type	i1	k	k1	l	L	m	p	q	s1	w1	y					
F 4	75	175	200	30	375	51,5	143	107	7	53	18,5					
F 9	75	175	200	30	375	51,5	143	107	7	53	18,5					
F 12	75	175	200	30	375	51,5	143	107	7	53	18,5					
F 16	75	175	200	30	375	51,5	143	107	7	53	18,5					
F 30	75	200	200	30	400	77,0	143	119	7	53	19,5					

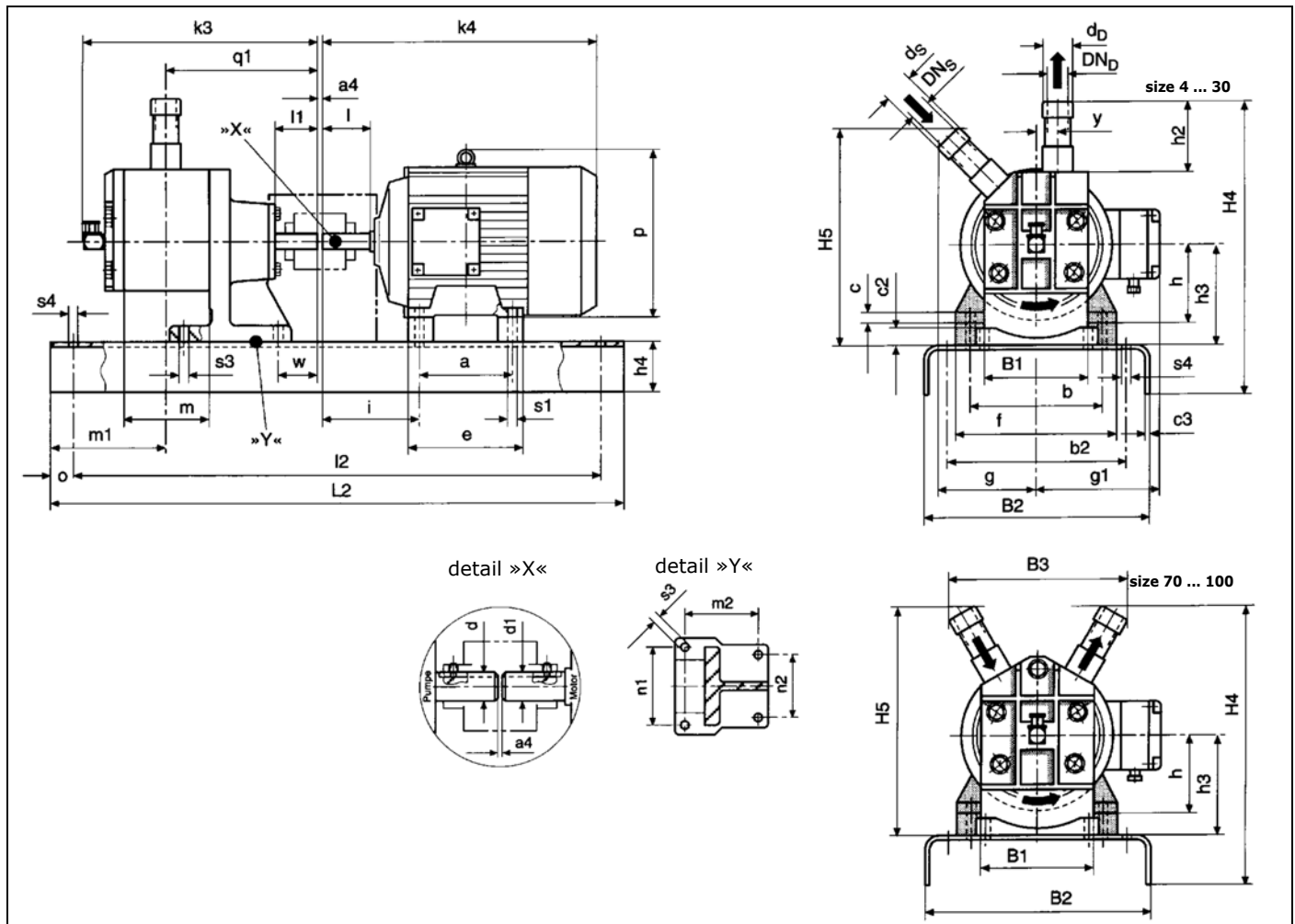
**Dimensions: type L**

type	suction side		pressure side		$P_N$ kW	$n_n$ $\text{min}^{-1}$	IEC size	design	weight <sup>1)</sup> (kg)
	DNs	ds	DNd	dd					
L 4	14	21	14	21	0,25	1450	71	B3	12,5
L 9	14	21	14	21	0,25	1450	71	B3	12,5
L12	14	21	14	21	0,25	1450	71	B3	12,5
L 16	19	27	19	27	0,25	1450	71	B3	12,5
L 30	24	34	19	27	0,37	1450	71	B3	14,0
L 70	29	40	29	40	0,75	960	90	B3	31,5
L 100	38	52	38	52	1,10	960	90	B3	34,5

1) pump with motor

type	dimensions (mm)																	
	a	a4	b	b2	B1	B2	B3	c	c2	c3	d	d1	e	f	g	g1	h	
L 4	90	10	112	165	92	205	-	9	19	4	11	14	125	138	80	111	71	
L 9	90	10	112	165	92	205	-	9	19	4	11	14	125	138	80	111	71	
L12	90	10	112	165	92	205	-	9	19	4	11	14	125	138	80	111	71	
L 16	90	10	112	165	92	205	-	9	19	4	11	14	125	138	80	111	71	
L 30	90	10	112	165	92	205	-	9	19	4	11	14	125	138	84	111	71	
L 70	100	2	125	260	153	300	220	11	37	5	22	24	130	170	-	139	90	
L 100	100	2	140	260	153	300	225	11	37	5	22	24	130	170	-	139	90	

type	dimensions (mm)																				
	h2	h3	h4	H4	H5	i	k3	k4	l	l1	l2	L2	m	m1	o	p	p1	s1	s4	w	y
L 4	60	90	45	275	190	75	181	231	30	23	460	500	51,5	123	20	143	115	7	10,5	21	18,5
L 9	60	90	45	275	190	75	181	231	30	23	460	500	51,5	123	20	143	115	7	10,5	21	18,5
L12	60	90	45	275	190	75	181	231	30	23	460	500	51,5	123	20	143	115	7	10,5	21	18,5
L 16	60	90	45	275	190	75	181	231	30	23	460	500	51,5	123	20	143	115	7	10,5	21	18,5
L 30	60	90	45	275	190	75	207	231	30	23	460	500	71,0	110	20	143	128	7	10,5	21	19,5
L 70	80	127	50	360	304	106	268	294	50	40	690	730	77,0	114	20	178	181	9	10,5	47	-
L 100	80	127	50	360	309	106	296	294	50	40	690	730	106,0	99	20	178	195	9	10,5	47	-

**Sectional drawing type F**

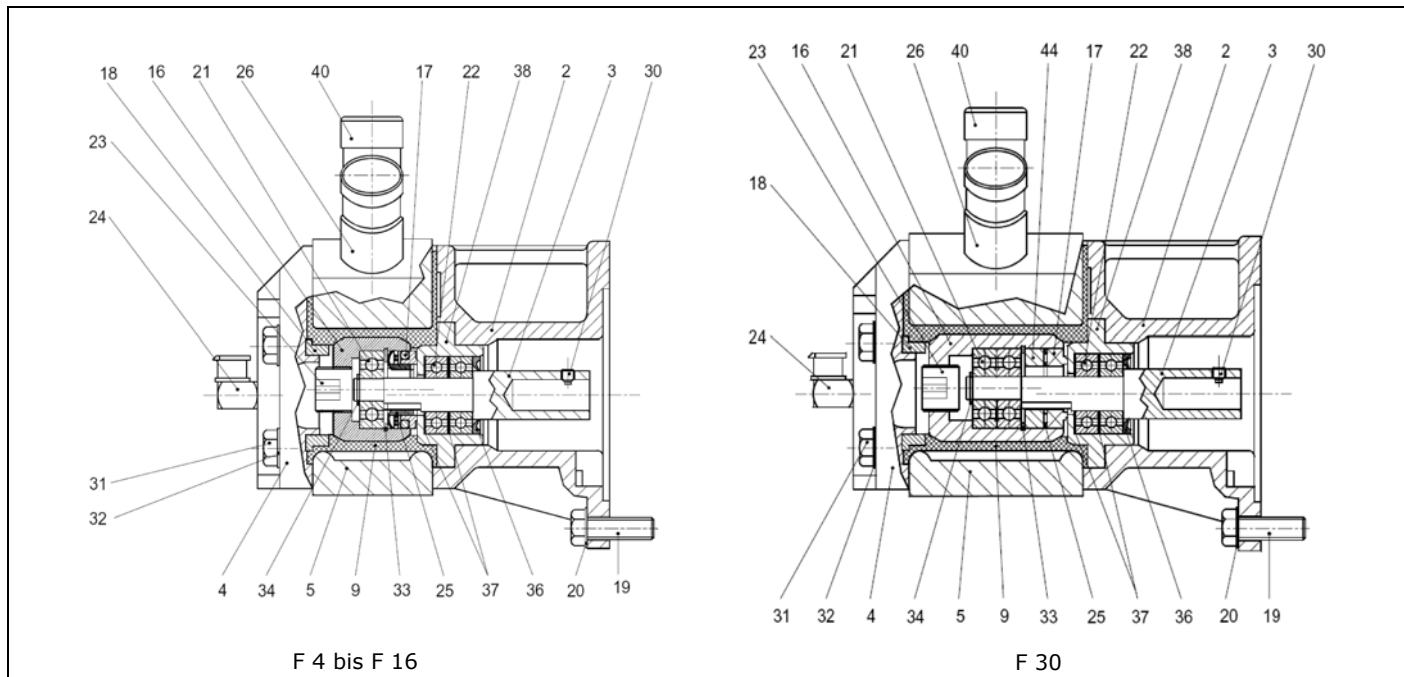

Item	Designation
2	Pump flange
3	Shaft
4	Cover plate
5	Housing compl.
5	Housing compl.
5	Housing compl.
9	Liner
9	Liner
9	Liner
9	Liner
9	Liner
9	Liner
16	Rotor
17	Mechanical seal
18	Expansion ring
19	Hexagonal screw
20	Washer
21	Radial ball bearing
22	Radial ball bearing
23	Plug screw
24	Oiler
25	Spacer washer
26	Suction socket
30	Threaded pin
31	Hexagonal screw
32	Spring washer
33	Circlip
34	Circlip
36	Shaft sealing ring
37	Shim ring
38	Bearing insert
40	Pressure socket
44	Spacer ring

## Sectional drawing type L

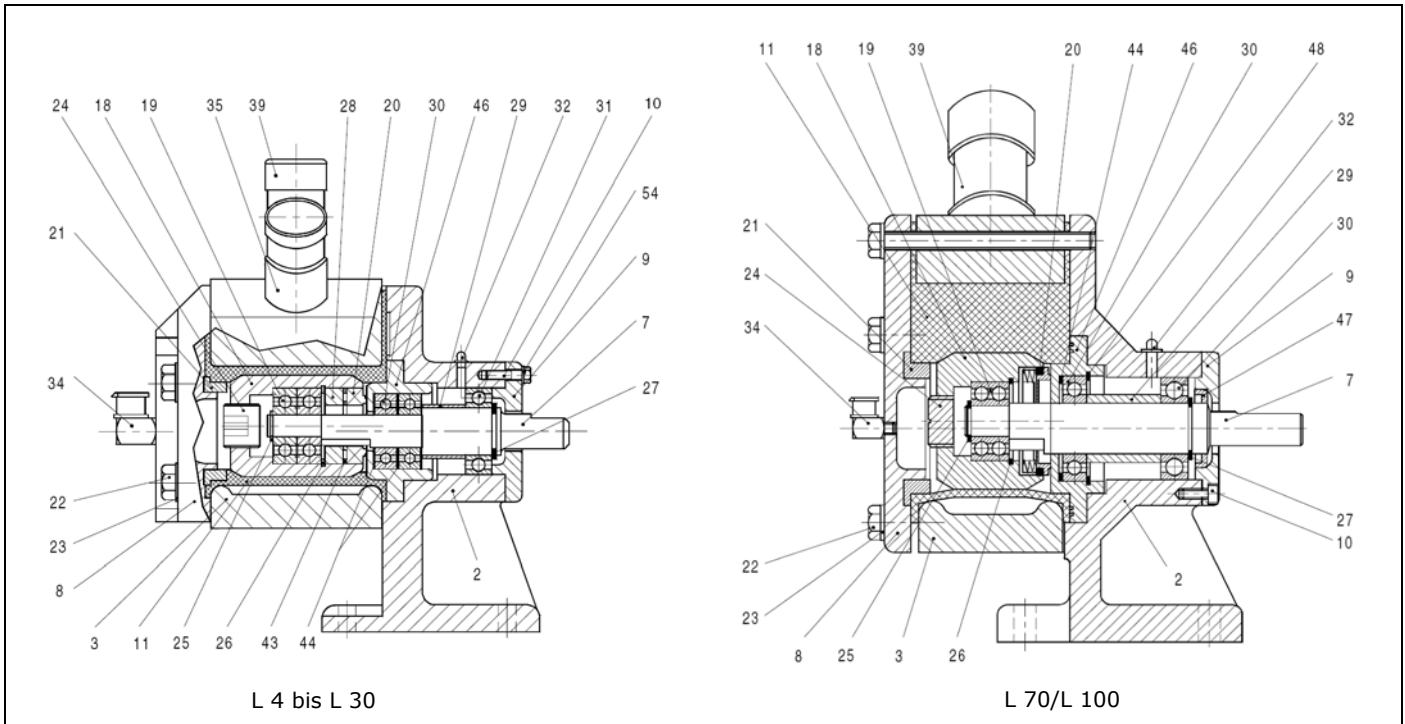

Item	Designation
2	Bearing block
3	Housing compl.
3	Housing compl.
3	Housing compl.
7	Shaft
8	Cover plate
9	Cover
10	Hexagonal screw
11	Liner
11	Liner
11	Liner
11	Liner
11	Liner
18	Rotor
19	Radial ball bearing
20	Mechanical seal
21	Expansion ring
22	Hexagonal screw
23	Washer
24	Closing screw
25	Circlip
26	Circlip
27	Circlip
28	Spacer ring
29	Bush
30	Radial ball bearing
31	Radial ball bearing
32	Ball grease nipple
34	Oiler
35	Suction socket
39	Pressure socket
43	Spacer washer
44	Shim ring
46	Bearing insert
47	Shaft sealing ring
48	Circlip
54	Washer

**Characteristic curves**

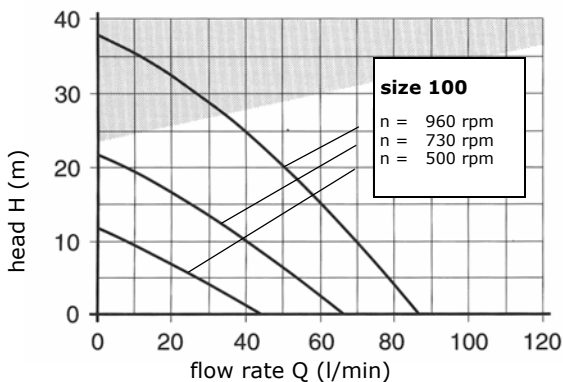
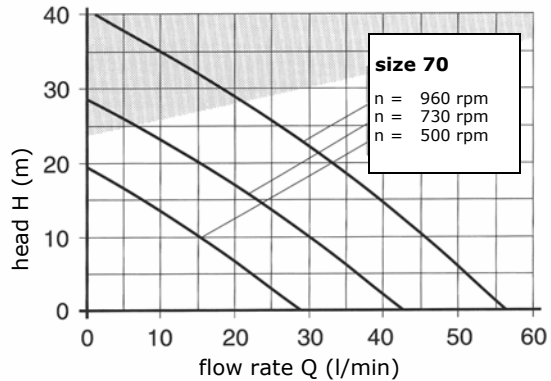
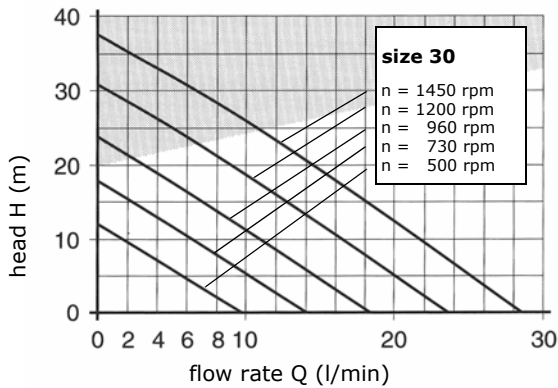
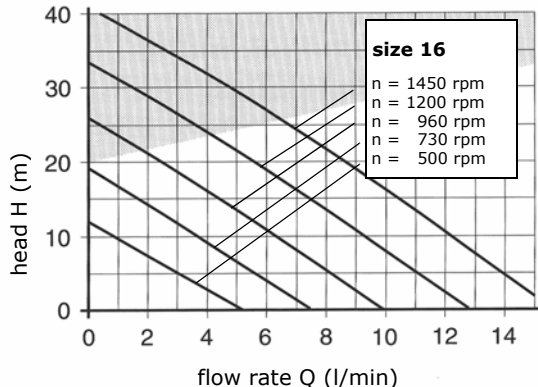
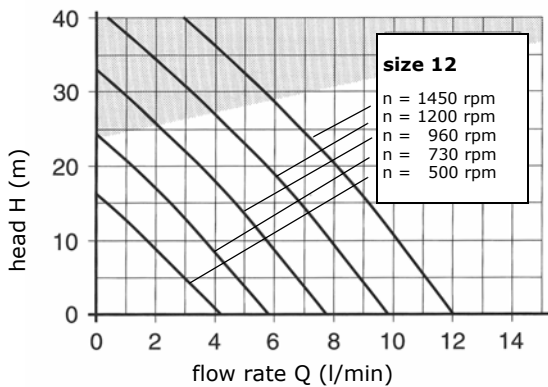
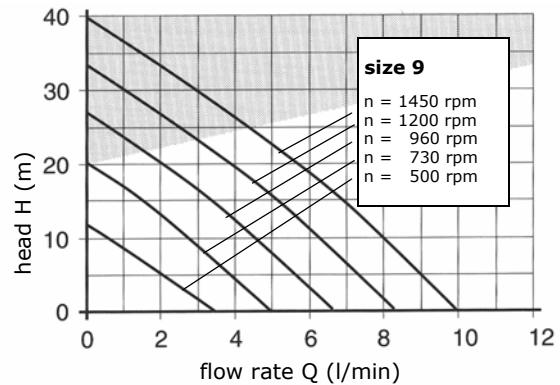
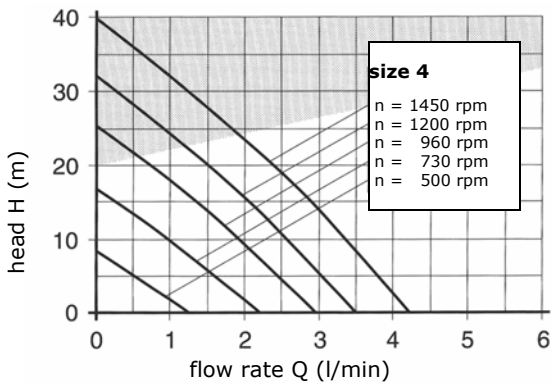

 **White field:**  
Area for continuous pump operation

 **Grey field:**  
Only for discontinuous (interrupted) or intermittent operation. According to the individual applications an unsmooth pump running can occur.

Please refer to the information contained in the chapter "Pump selection" and allow the qualified ASV engineers to assist you when selecting the suitable pump size in accordance with the operating conditions to be expected.

Subject to technical modifications