

Kreiselpumpen Typ T  
Centrifugal pumps type T

**KNOLL**

.It works



Ausgabe | Issue | 11-2010

**Atelier certifié pour la réparation des pompes soumises à réglementation ATEX**



**ZAC du Moulin**

**Rue Boucher**

**76410 Cléon - France**

**Téléphone : 02 35 74 48 98**

**Email : [info@eco-tech.pro](mailto:info@eco-tech.pro)**

**[www.eco-tech.fr](http://www.eco-tech.fr)**

# KNOLL-Service weltweit KNOLL Service worldwide



Produkte von KNOLL sind weltweit im Einsatz, Service ist eine tragende Säule unseres Erfolgs. Wir bieten zeitnahe und schlüssige Diagnose bei auftretenden Störungen und Ausfällen. Im Bedarfsfall entsenden wir unsere Servicetechniker kurzfristig an den Einsatzort.

Dass unsere Kunden effektive Unterstützung erhalten, ist für uns selbstverständlich. Ob bei Ihnen vor Ort oder in unserem Pumpen-Reparatur-Center: Das KNOLL-Reparaturteam unterzieht die

Pumpen einer sorgfältigen Diagnose und setzt sie schnellstmöglich wieder instand.

Unser Ersatzteillager hat die gängigsten Verschleiß- und Ersatzteile abrufbar vorrätig zum schnellen Versand und zur kurzfristigen Montage. Die KNOLL-Ersatzpumpe erhalten Sie im Bedarfsfall europaweit innerhalb von 24 h oder holen diese direkt bei uns im Stammhaus ab.



KNOLL products are used around the world, service is the cornerstone of our success. We offer contemporary and conclusive diagnosis in the event of faults and malfunctions. Where necessary we dispatch our service engineers at short notice to the sites where they are needed.

It goes without saying that our customers should receive effective support. Whether it be on site or at our pump repair center: the KNOLL repair team subjects the pumps to meticulous diag-

nosis and repairs them as quickly as possible.

We stock the most in-demand wear and spare parts for rapid dispatch and for short-term installation. Where necessary, a KNOLL replacement pump will reach you throughout Europe within 24 hours or can be collected directly from our company headquarters.

## Eigenschaften. Properties.

# 1.

Sehr hoher Wirkungsgrad durch strömungstechnisch günstig geformtes Laufrad

Very high efficiency because of flow favorable formed impeller

# 2.

Hohe Belastbarkeit aufgrund solider Wellen-Nabenverbindung

High rigidity with its solid shaft-hub connection

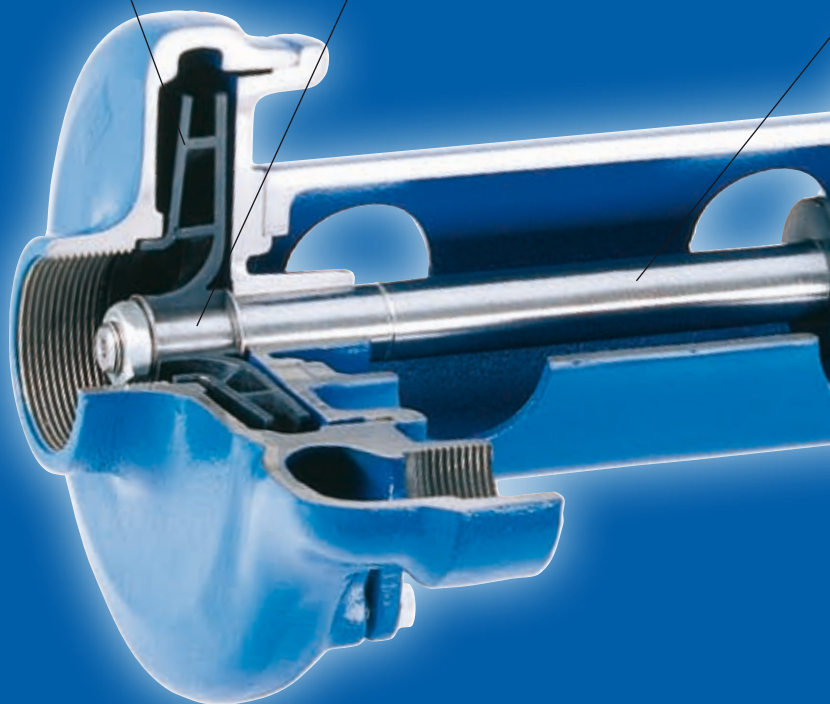

## Einsatzbereiche

KNOLL-Kreiselpumpen sind Tauchpumpen, die, auf drucklose Behälter oder Schächte montiert, in das Medium eintauchen. Sie werden hauptsächlich an Werkzeugmaschinen zur Kühlschmierstoffversorgung und -reinigung sowie an Reinigungs-/Entfettungsanlagen eingesetzt.

Es gibt 5 unterschiedliche Bauarten:

### Typ TG mit geschlossenem Laufrad

Für vorgereinigte KSS. Volumenstrom bis 1600 l/min, Druck bis 6 bar, Korngröße bis 3 mm.

### Typ TGM mit geschlossenen Laufrädern

Für verschmutzte KSS. Volumenstrom bis 1100 l/min, Druck bis 5,5 bar, Korngröße bis 15 mm.

### Typ TF mit Freistromlaufrad

Für verschmutzte KSS. Volumenstrom bis 1000 l/min, Druck bis 2,4 bar, Korngröße bis 30 mm.

### Typ TS mit Schraubenlaufrad

Für verschmutzte und lufthaltige KSS. Volumenstrom bis 600 l/min, Druck bis 1,8 bar, Korngröße bis 15 mm.

### Typ TSK mit kurzem Schraubenlaufrad

Für stark verschmutzte KSS mit abrasiven Spänen. Volumenstrom bis 700 l/min, Druck bis 1,7 bar, Korngröße bis 20 mm.

## Konstruktion

### Bauart

- Vertikale Bauform
- Normalsaugend, einstufig, dichtungslos
- Verlängerte, fliegend gelagerte Motorwelle mit Spritzring
- Druckstufen radial, nach oben abgewinkelt, Saugstutzen axial
- Mit Pumpenblech und Druckrohr

### Antrieb

Drehstrommotor

Bauart V 18, Schutzart IP 54, Isolierstoffklasse F

- 220-240 V (Δ) / 380-420 V (Y), 50 Hz, 2900 min<sup>-1</sup> | bis 3 kW
- 220-265 V (Δ) / 380-460 V (Y), 60 Hz, 3500 min<sup>-1</sup> |
- 380-420 V (Δ) / 660-725 V (Y), 50 Hz, 2900 min<sup>-1</sup> | ab 4 kW
- 380-480 V (Δ) / 660-830 V (Y), 60 Hz, 3500 min<sup>-1</sup> |

# 3.

Trockenlaufsicherheit durch  
fliegend gelagerte Welle

Safe of dry running because  
of taper bore mounting

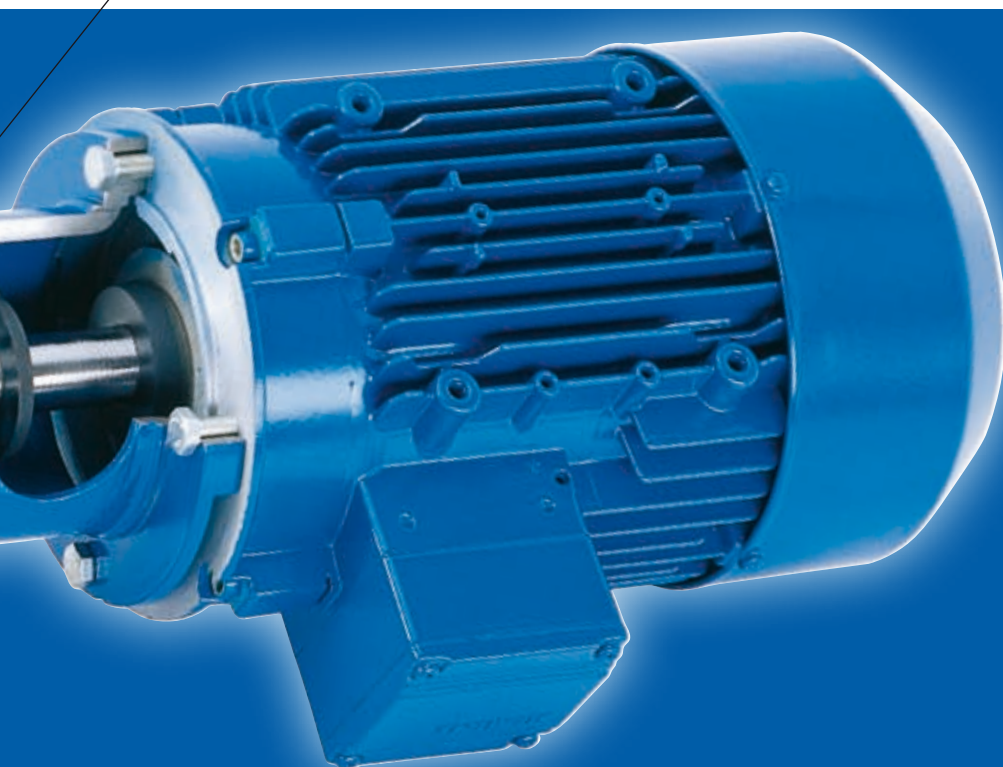

## Areas of application

KNOLL centrifugal pumps are suitable for immersion into the medium. They can be mounted on pressureless tanks or chutes. The pumps are applied at machine tools for supply with cleaning of cooling lubricant as well as application on cleaning equipment and degreasing units.

There are 5 different types available:

### **Type TG with closed impeller**

For precleaned coolant lubricant, volume flow up to 1600 l/min, pressure up to 6 bar, grain size up to 3 mm.

### **Type TGM with closed impellers**

For dirt coolant lubricant, volume flow up to 1100 l/min, pressure up to 5.5 bar, grain size up to 15 mm.

### **Type TF with open impeller**

For dirt coolant lubricant, volume flow up to 1000 l/min, pressure up to 2.4 bar, grain size up to 30 mm.

### **Type TS with helical impeller**

For dirt and aerated coolant lubricant, volume flow up to 600 l/min, pressure up to 1.8 bar, grain size up to 15 mm.

### **Type TSK with short helical impeller**

For very dirt coolant lubricant with abrasive chips, volume flow up to 700 l/min, pressure up to 1.7 bar, grain size up to 20 mm.

## Construction

### Type

- Vertical design
- Normal suction, single stage, without sealing
- Extended taper bore mounted motor axle with centrifuge ring
- Pressure connection is radial and bent upwards, suction connection is axial
- With pump plate and pressure pipe

### Drive

Three-phase motor

Type V 18, protection IP 54, insulated material class F

- 220-240 V (Δ) / 380-420 V (Y), 50 Hz, 2900 min<sup>-1</sup> | up to 3 kW
- 220-265 V (Δ) / 380-460 V (Y), 60 Hz, 3500 min<sup>-1</sup> |
- 380-420 V (Δ) / 660-725 V (Y), 50 Hz, 2900 min<sup>-1</sup> | from 4 kW
- 380-480 V (Δ) / 660-830 V (Y), 60 Hz, 3500 min<sup>-1</sup> |

## Reinmediumpumpen Typ TG Pure medium pumps Typ TG

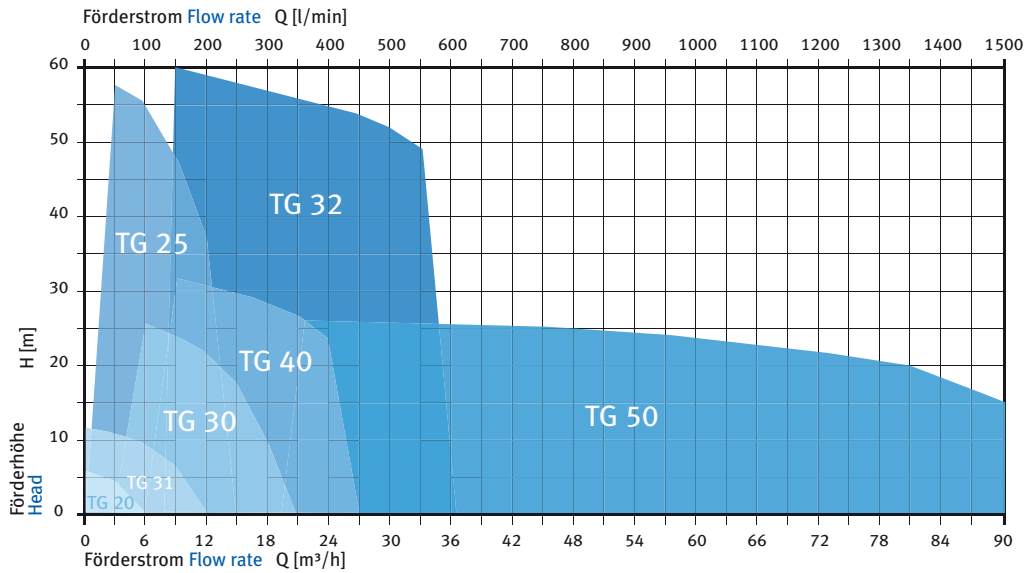

## Schmutzmediumpumpen mehrstufig Typ TGM Dirt medium pumps multi stage Typ TGM

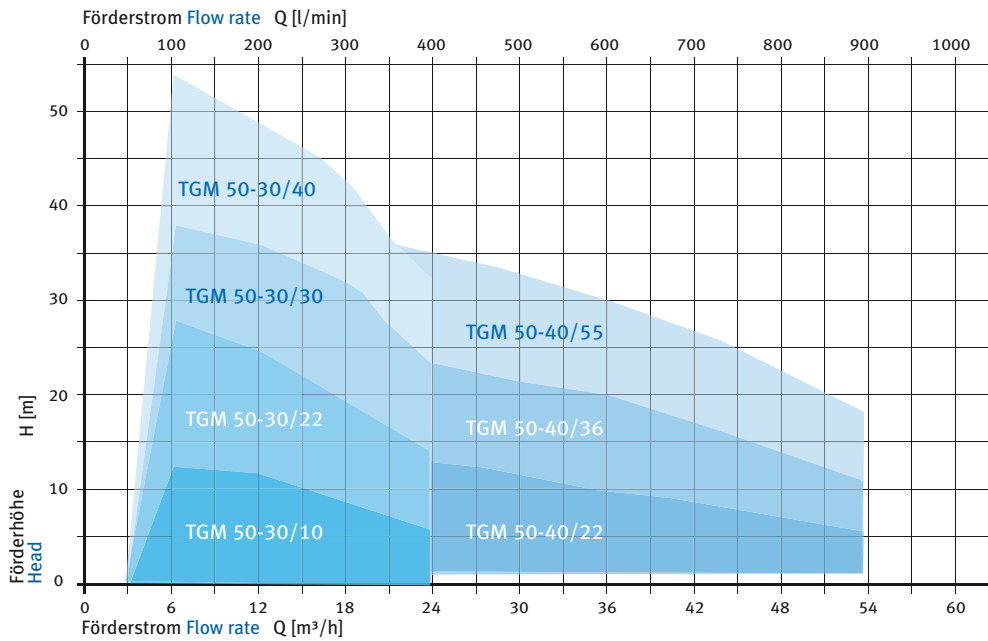

## Schmutzmediumpumpen Typ TF, TS, TSK Dirt medium pumps Typ TF, TS, TSK

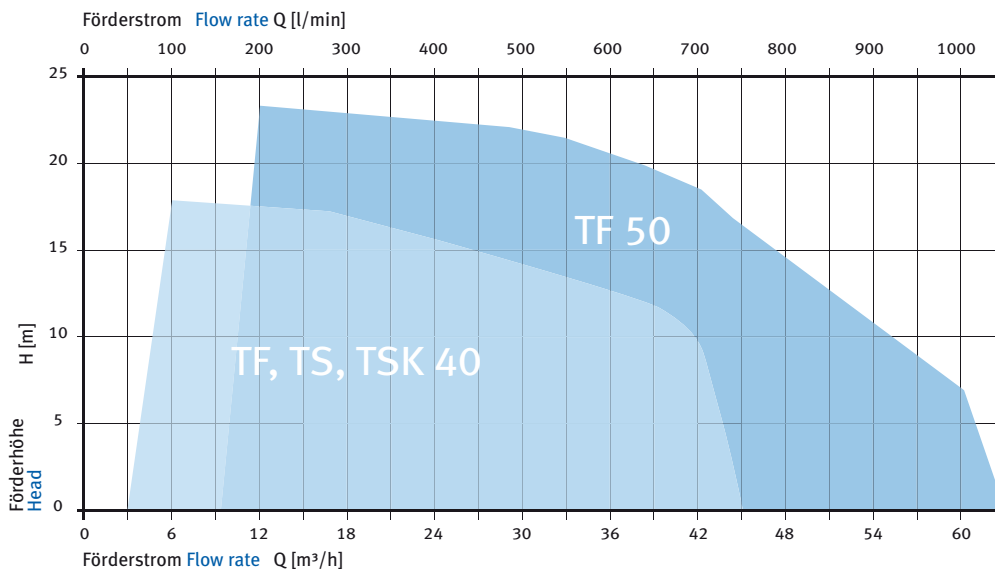

# TG 20

Nenn Drehzahl /  
Nominal rotation speed **2900 min<sup>-1</sup> @ 50 Hz**

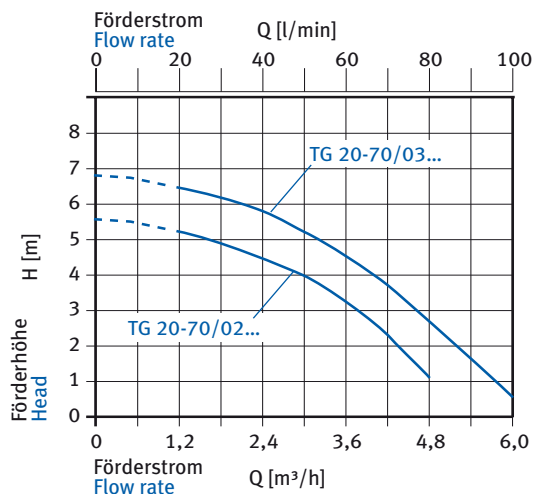

Typ/Type	T (mm)	H (mm)	G (mm)	Gewicht Weight (kg)	Motorleistung Motor power (kW)
TG 20-70/02 220	220	215	127	7,2	0,25
TG 20-70/03 220	220	215	127	7,7	0,33
TG 20-70/02 350	350	215	127	8,1	0,25
TG 20-70/03 350	350	215	127	8,6	0,33

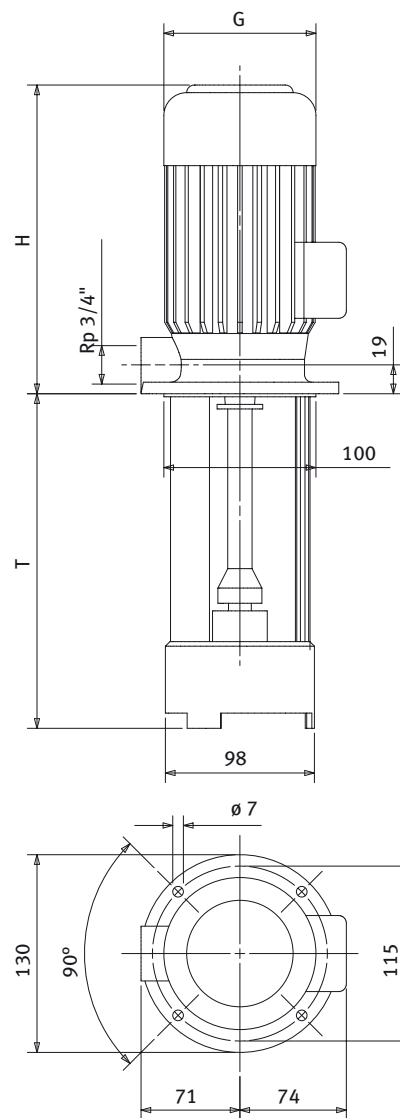

Nenn Drehzahl /  
Nominal rotation speed **3500 min<sup>-1</sup> @ 60 Hz**

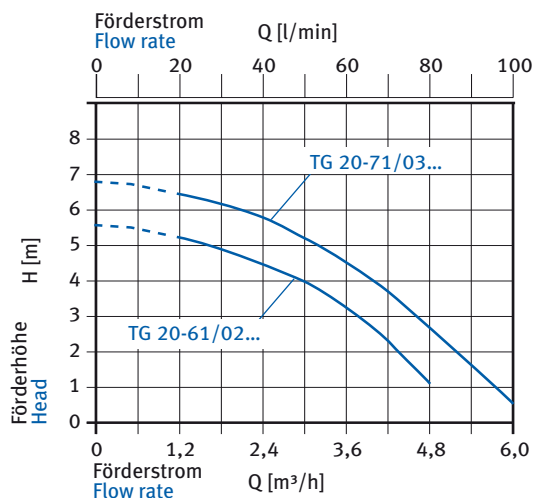

Typ/Type	T (mm)	H (mm)	G (mm)	Gewicht Weight (kg)	Motorleistung Motor power (kW)
TG 20-61/02 220	220	215	127	7,2	0,25
TG 20-71/03 220	220	215	127	7,7	0,33
TG 20-61/02 350	350	215	127	8,1	0,25
TG 20-71/03 350	350	215	127	8,6	0,33

Tauchpumpe — TG 20-70/02 220  
 Laufradform —  
 Baugröße —  
 Laufrad-Index —  
 Motorleistung x 10 —  
 Eintauchtiefe in mm —

Submerged pump — TG 20-70/02 220  
 Form of impeller —  
 Pump size —  
 Impeller-index —  
 Motor power x 10 —  
 Depth of immersion in mm —

Max. Korngröße: 1 mm  
 Laufrad-Werkstoff: PBT  
 Kennlinien für  $\nu = 1 \text{ mm}^2/\text{s}$

Max. grain size: 1 mm  
 Impeller material: PBT  
 Characteristic lines for  $\nu = 1 \text{ mm}^2/\text{s}$

# TG 25

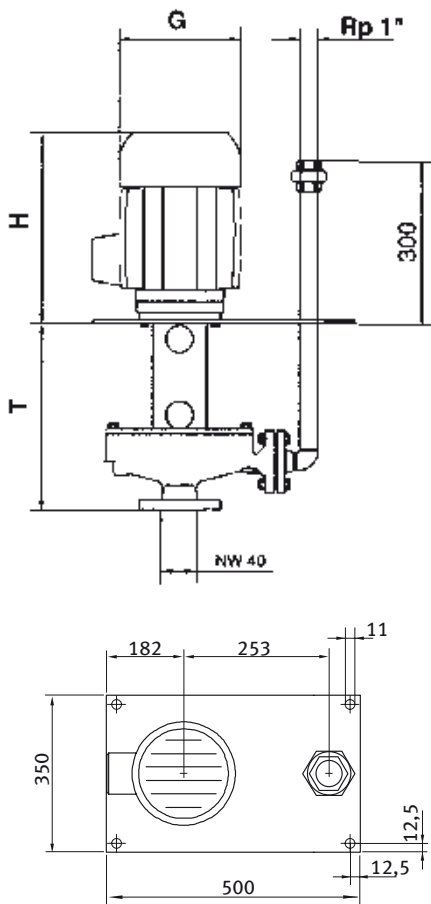

Typ/Type	T (mm)	H (mm)	G (mm)	Gewicht Weight (kg)	Motorleistung Motor power (kW)
TG 25-../22 345	345	320	180	47	2,2
TG 25-../30 345	345	350	200	49	3,0
TG 25-../22 590	590	320	180	51	2,2
TG 25-../30 590	590	350	200	53	3,0

Beispiel: Laufrad- $\varnothing$  = 158  $\rightarrow$  TG 25-58/22 345

Example: Impeller- $\varnothing$  = 158  $\rightarrow$  TG 25-58/22 345

Tauchpumpe — TG 25-58/22 345  
 Laufradform —  
 Baugröße —  
 Laufrad-Index —  
 Motorleistung x 10 —  
 Eintauchtiefe in mm —

Submerged pump — TG 25-58/22 345  
 Form of impeller —  
 Pump size —  
 Impeller-index —  
 Motor power x 10 —  
 Depth of immersion in mm —

## Neendrehzahl / Nominal rotation speed 2900 min<sup>-1</sup> @ 50 Hz

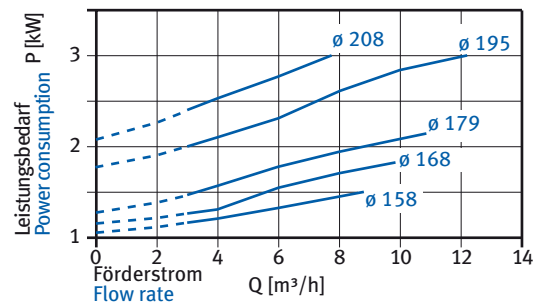
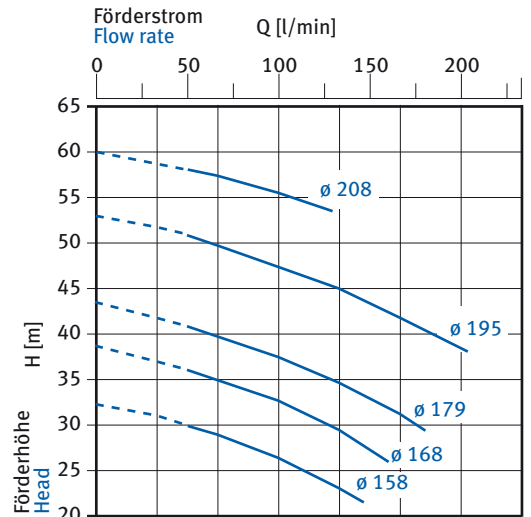

## Neendrehzahl / Nominal rotation speed 3500 min<sup>-1</sup> @ 60 Hz

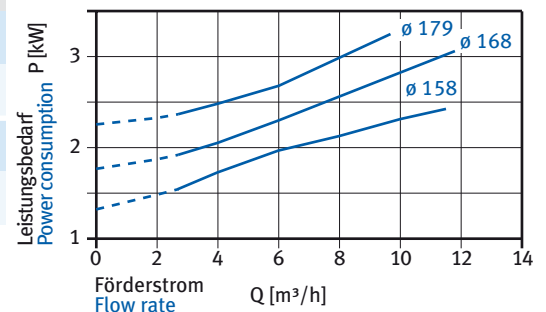
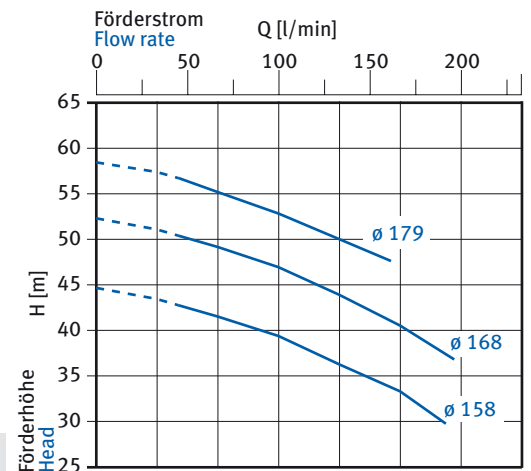

Max. Korngröße: 1 mm  
 Laufrad-Werkstoff: GJL-250 (GG 25)  
 Kennlinien für  $\nu = 1 \text{ mm}^2/\text{s}$

Max. grain size: 1 mm  
 Impeller material: GJL-250 (GG 25)  
 Characteristic lines for  $\nu = 1 \text{ mm}^2/\text{s}$



# TG 30

Nennzahl /  
Nominal rotation speed 2900 min<sup>-1</sup> @ 50 Hz

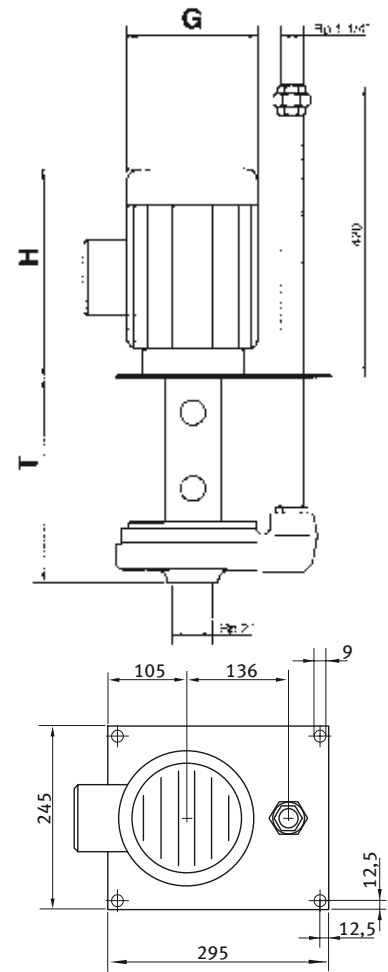
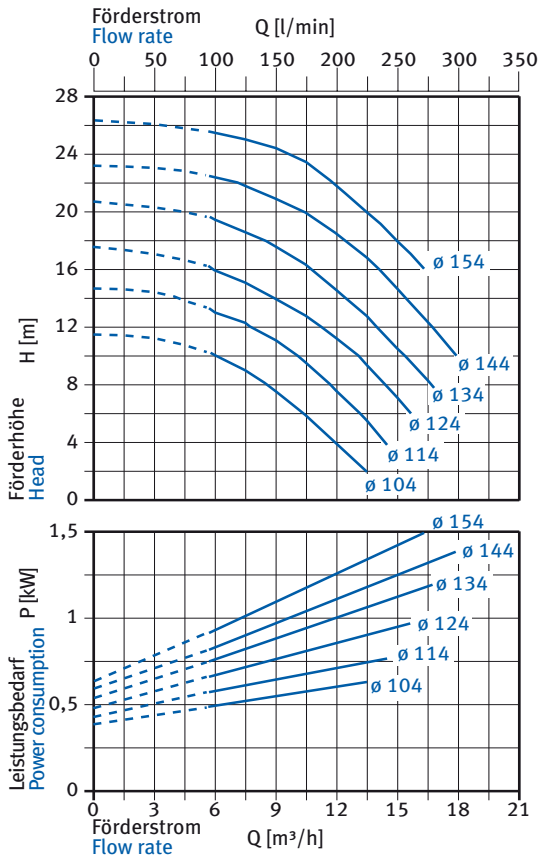

Nennzahl /  
Nominal rotation speed 3500 min<sup>-1</sup> @ 60 Hz

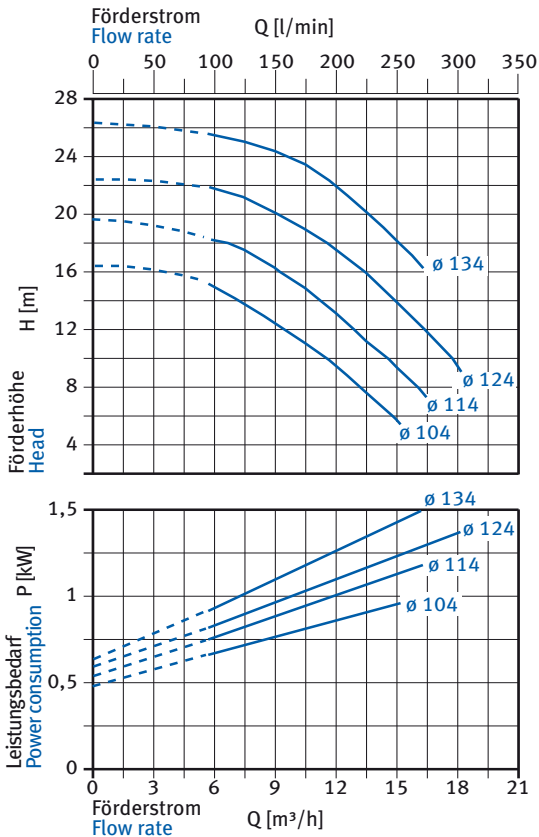

Typ/Type	T (mm)	H (mm)	G (mm)	Gewicht/Weight (kg)	Motorleistung/Motor power (kW)
TG 30-../07 285	285	270	160	23	0,75
TG 30-../11 285	285	270	160	24	1,1
TG 30-../15 285	285	290	180	27	1,5
TG 30-../07 533	533	270	160	30	0,75
TG 30-../11 533	533	270	160	31	1,1
TG 30-../15 533	533	290	180	34	1,5
TG 30-../15 781	781	290	180	41	1,5

Beispiel: Laufrad-Ø = 154 → TG 30-54/15 285

Example: Impeller-Ø = 154 → TG 30-54/15 285

Tauchpumpe — TG 30-54/15 285  
Laufradform  
Baugröße  
Laufrad-Index  
Motorleistung x 10  
Eintauchtiefe in mm

Submerged pump — TG 30-54/15 285  
Form of impeller  
Pump size  
Impeller-index  
Motor power x 10  
Depth of immersion in mm

Max. Korngröße: 1 mm  
Laufrad-Werkstoff: POM  
Kennlinien für  $v = 1 \text{ mm}^2/\text{s}$

Max. grain size: 1 mm  
Impeller material: POM  
Characteristic lines for  $v = 1 \text{ mm}^2/\text{s}$

# TG 31

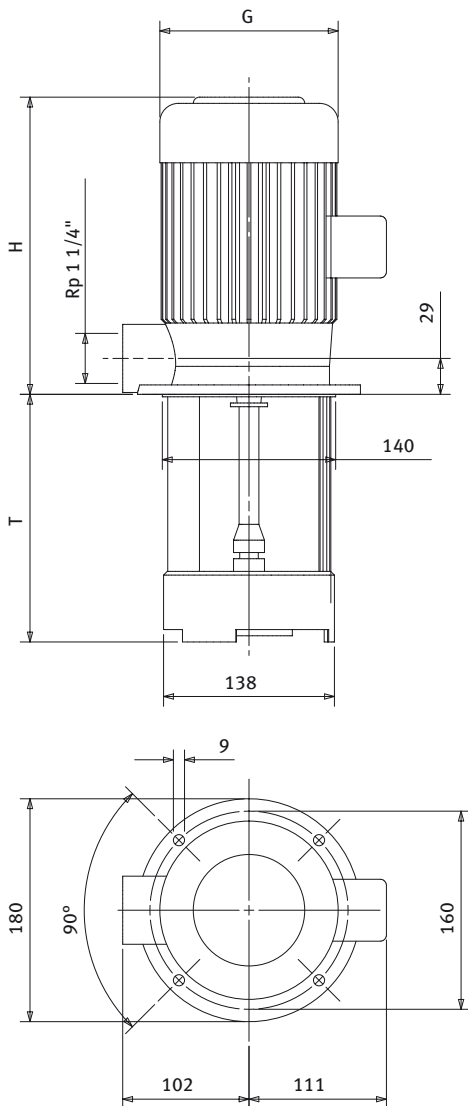

**Nenn Drehzahl /**  
**Nominal rotation speed** 2900 min<sup>-1</sup> @ 50 Hz

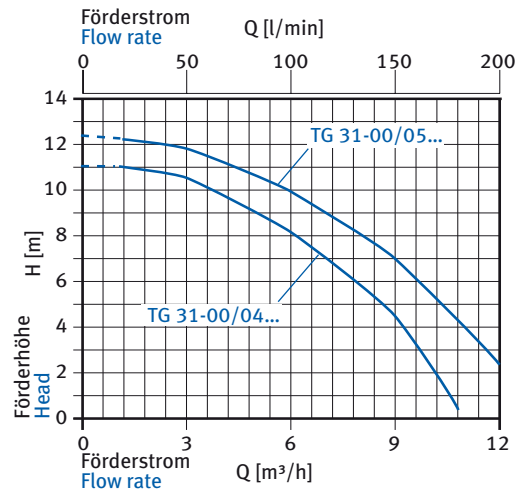

Typ/Type	T (mm)	H (mm)	G (mm)	Gewicht Weight (kg)	Motorleistung Motor power (kW)
TG 31-00/04 200	200	250	144	13,6	0,37
TG 31-00/05 200	200	250	144	14,5	0,55
TG 31-00/04 350	350	250	144	15,1	0,37
TG 31-00/05 350	350	250	144	16,0	0,55
TG 31-00/04 550	550	250	144	17,1	0,37
TG 31-00/05 550	550	250	144	18,0	0,55

**Nenn Drehzahl /**  
**Nominal rotation speed** 3500 min<sup>-1</sup> @ 60 Hz

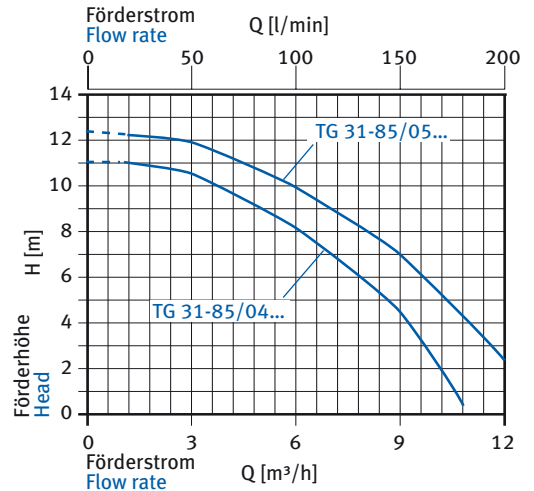

Typ/Type	T (mm)	H (mm)	G (mm)	Gewicht Weight (kg)	Motorleistung Motor power (kW)
TG 31-85/04 200	200	250	144	13,6	0,37
TG 31-85/05 200	200	250	144	14,5	0,55
TG 31-85/04 350	350	250	144	15,1	0,37
TG 31-85/05 350	350	250	144	16,0	0,55
TG 31-85/04 550	550	250	144	17,1	0,37
TG 31-85/05 550	550	250	144	18,0	0,55

Tauchpumpe — TG 31-00/05 200  
 Laufradform —  
 Baugröße —  
 Laufrad-Index —  
 Motorleistung x 10 —  
 Eintauchtiefe in mm —

Submerged pump — TG 31-00/05 200  
 Form of impeller —  
 Pump size —  
 Impeller-index —  
 Motor power x 10 —  
 Depth of immersion in mm —

Max. Korngröße: 1 mm  
 Laufrad-Werkstoff: PBT  
 Kennlinien für  $\nu = 1 \text{ mm}^2/\text{s}$

Max. grain size: 1 mm  
 Impeller material: PBT  
 Characteristic lines for  $\nu = 1 \text{ mm}^2/\text{s}$

# TG 32

**Nenn Drehzahl /**  
**Nominal rotation speed 2900 min<sup>-1</sup> @ 50 Hz**

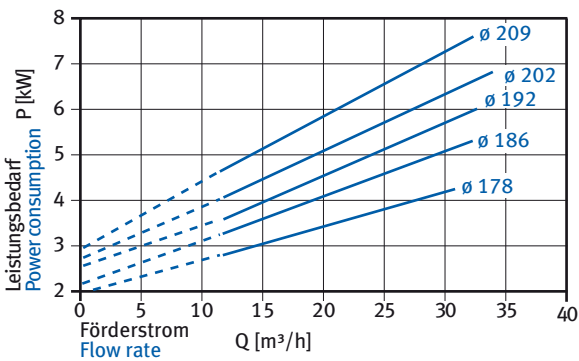
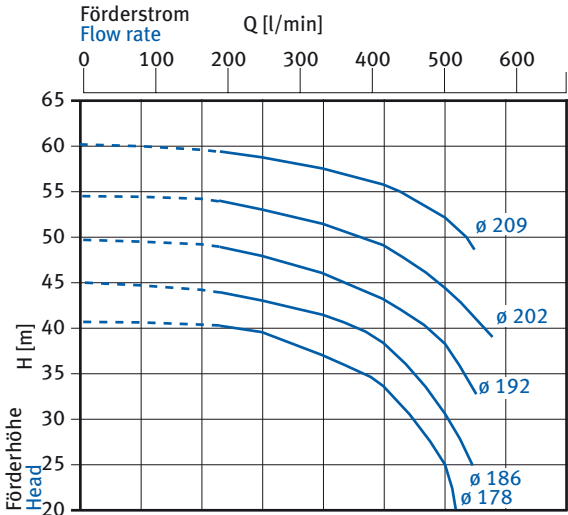

**Nenn Drehzahl /**  
**Nominal rotation speed 3500 min<sup>-1</sup> @ 60 Hz**

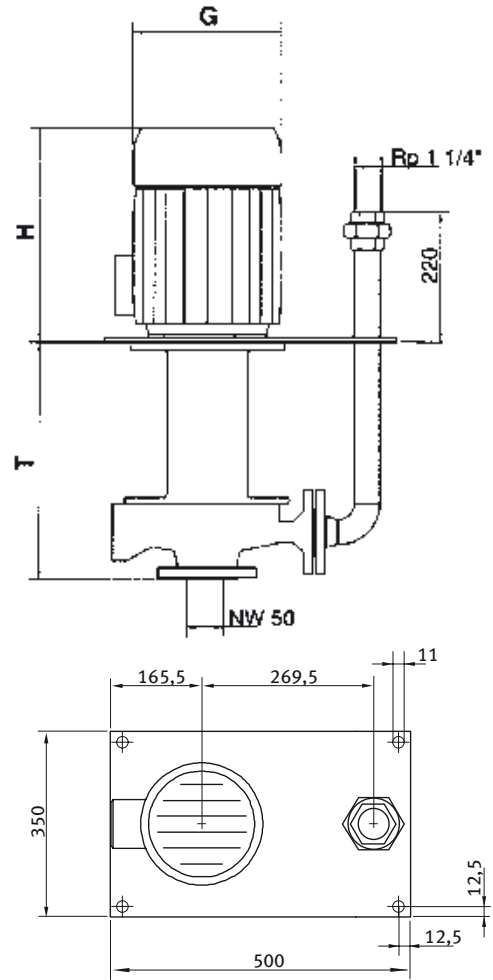
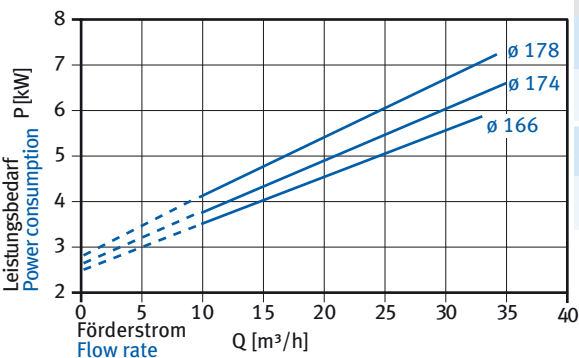
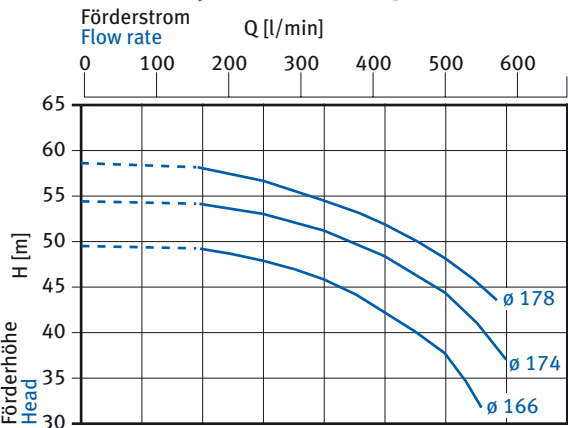

Typ/Type	T (mm)	H (mm)	G (mm)	Gewicht/Weight (kg)	Motorleistung/Motor power (kW)
TG 32-../55 400	400	370	252	100	5,5
TG 32-../75 400	400	370	252	106	7,5
TG 32-../55 700	700	370	252	127	5,5
TG 32-../75 700	700	370	252	133	7,5

Beispiel: Laufrad-Ø = 178--> TG 32-78/75 700

Example: Impeller-Ø = 178--> TG 32-78/75 700

Tauchpumpe — TG 32-78/75 700  
 Laufradform  
 Baugröße  
 Laufrad-Index  
 Motorleistung x 10  
 Eintauchtiefe in mm

Submerged pump — TG 32-78/75 700  
 Form of impeller  
 Pump size  
 Impeller-index  
 Motor power x 10  
 Depth of immersion in mm

Max. Korngröße: 2 mm  
 Laufrad-Werkstoff: GJL-250 (GG 25)  
 Kennlinien für  $\nu = 1 \text{ mm}^2/\text{s}$

Max. grain size: 2 mm  
 Impeller material: GJL-250 (GG 25)  
 Characteristic lines for  $\nu = 1 \text{ mm}^2/\text{s}$

# TG 40

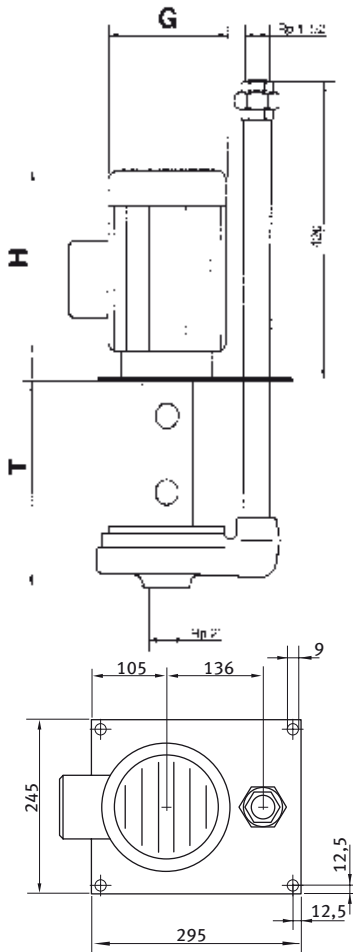

Typ/Type	T (mm)	H (mm)	G (mm)	Gewicht Weight (kg)	Motorleistung Motor power (kW)
TG 40-../11 285	285	270	160	25	1,1
TG 40-../15 285	285	290	180	28	1,5
TG 40-../22 285	285	320	180	31	2,2
TG 40-../30 285	285	350	200	35	3,0
TG 40-../11 533	533	270	160	32	1,1
TG 40-../15 533	533	290	180	35	1,5
TG 40-../22 533	533	320	180	38	2,2
TG 40-../30 533	533	350	200	42	3,0
TG 40-../15 781	781	290	180	42	1,5
TG 40-../22 781	781	320	180	45	2,2
TG 40-../30 781	781	350	200	49	3,0

Beispiel: Laufrad-Ø = 155 → TG 40-55/30 285

Example: Impeller-Ø = 155 → TG 40-55/30 285

Tauchpumpe — TG 40-55/30 285  
 Laufradform —  
 Baugröße —  
 Laufrad-Index —  
 Motorleistung x 10 —  
 Eintauchtiefe in mm —

Submerged pump — TG 40-55/30 285  
 Form of impeller —  
 Pump size —  
 Impeller-index —  
 Motor power x 10 —  
 Depth of immersion in mm —

## Nennndrehzahl / Nominal rotation speed 2900 min<sup>-1</sup> @ 50 Hz

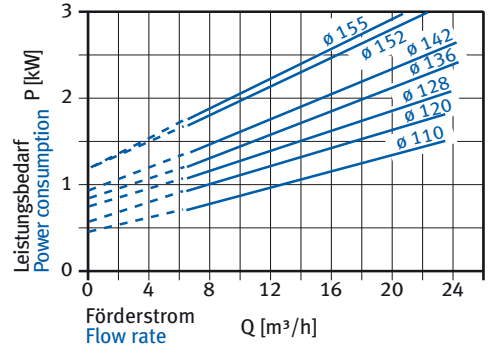
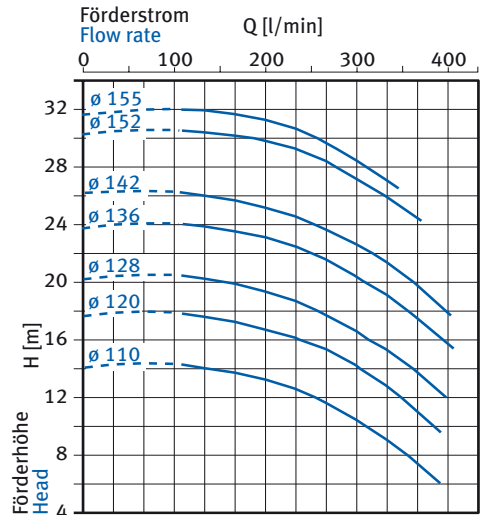

## Nennndrehzahl / Nominal rotation speed 3500 min<sup>-1</sup> @ 60 Hz

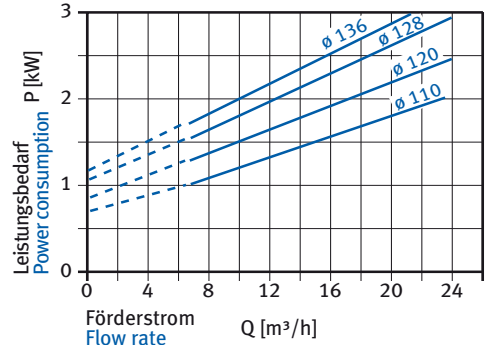
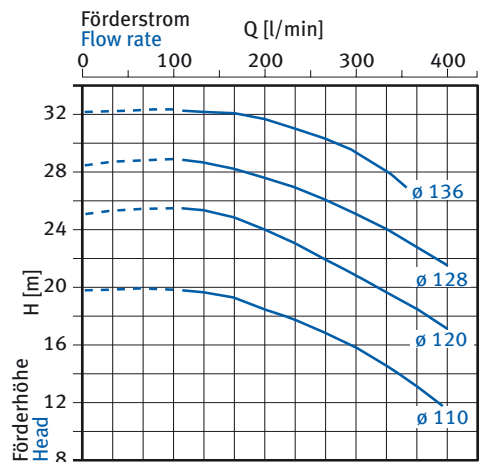

Max. Korngröße: 3 mm  
 Laufrad-Werkstoff: POM/GJL-250 (GG 25)  
 Kennlinien für  $\nu = 1 \text{ mm}^2/\text{s}$

Max. grain size: 3 mm  
 Impeller material: POM/GJL-250 (GG 25)  
 Characteristic lines for  $\nu = 1 \text{ mm}^2/\text{s}$

# TG 50

**Nenn Drehzahl /**  
**Nominal rotation speed 2900 min<sup>-1</sup> @ 50 Hz**

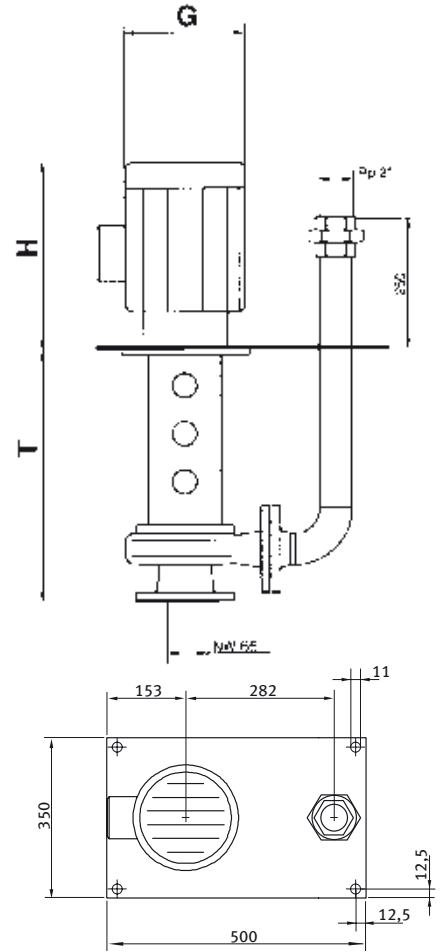
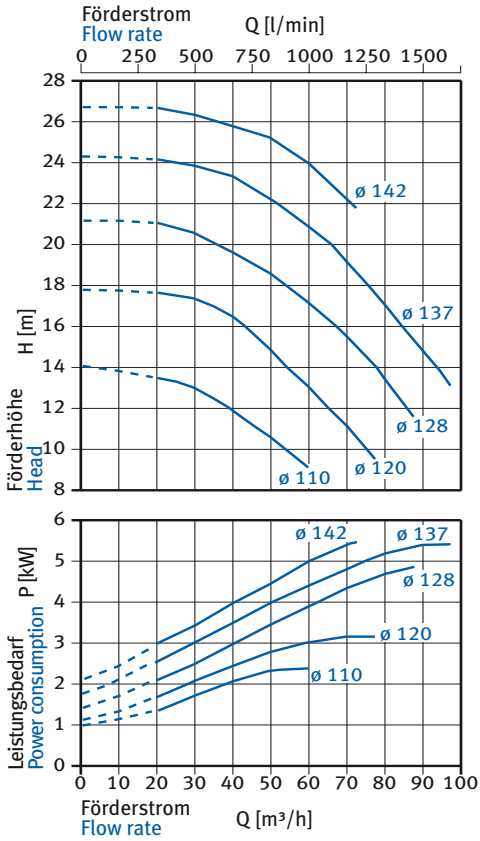

**Nenn Drehzahl /**  
**Nominal rotation speed 3500 min<sup>-1</sup> @ 60 Hz**

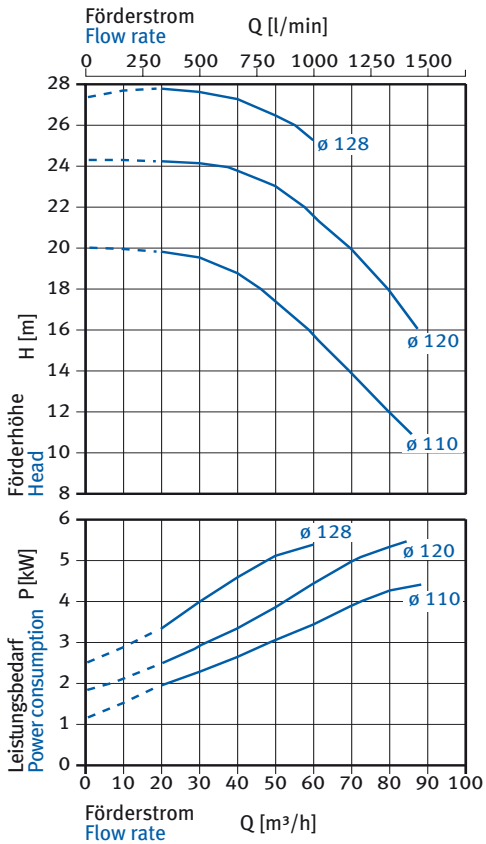

Typ/Type	T (mm)	H (mm)	G (mm)	Gewicht/Weight (kg)	Motorleistung/Motor power (kW)
TG 50-../40 480	480	355	224	68	4,0
TG 50-../55 480	480	355	224	78	5,5
TG 50-../40 840	840	355	224	75	4,0
TG 50-../55 840	840	355	224	85	5,5

Beispiel: Laufrad-Ø = 128 → TG 50-28/55 480

Example: Impeller-Ø = 128 → TG 50-28/55 480

Tauchpumpe — TG 50-28/55 480  
 Laufradform —  
 Baugröße —  
 Laufrad-Index —  
 Motorleistung x 10 —  
 Eintauchtiefe in mm —

Submerged pump — TG 50-28/55 480  
 Form of impeller —  
 Pump size —  
 Impeller-index —  
 Motor power x 10 —  
 Depth of immersion in mm —

Max. Korngröße: 15 mm  
 Laufrad-Werkstoff: GJL-250 (GG 25)  
 Kennlinien für  $\nu = 1 \text{ mm}^2/\text{s}$

Max. grain size: 15 mm  
 Impeller material: GJL-250 (GG 25)  
 Characteristic lines for  $\nu = 1 \text{ mm}^2/\text{s}$

# TGM 50-30

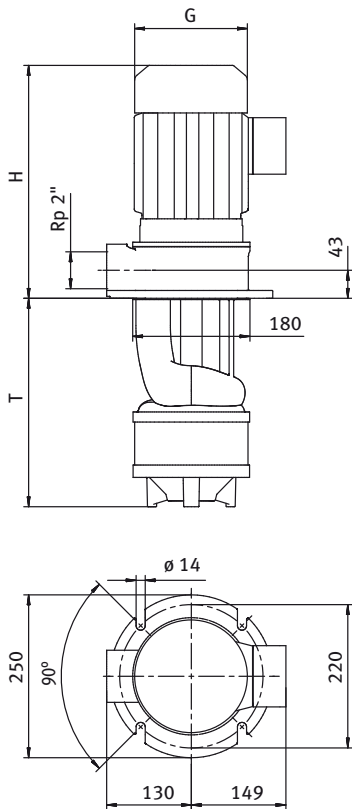

Typ/Type	T (mm)	H (mm)	G (mm)	Gewicht/Weight (kg)	Motorleistung/Motor power (kW)
TGM 50-../10 250	250	305	140	30	1,0
TGM 50-../10 320	320	305	140	32	1,0
TGM 50-../10 450	450	305	140	34	1,0
TGM 50-../10 550	550	305	140	36	1,0
TGM 50-../22 320	320	348	176	42	2,2
TGM 50-../22 390	390	348	176	44	2,2
TGM 50-../22 520	520	348	176	46	2,2
TGM 50-../22 620	620	348	176	48	2,2
TGM 50-../30 390	390	348	176	53	3,0
TGM 50-../30 460	460	348	176	55	3,0
TGM 50-../30 590	590	348	176	56	3,0
TGM 50-../40 460	460	380	196	62	4,0
TGM 50-../40 530	530	380	196	64	4,0
TGM 50-../40 660	660	380	196	65	4,0

Max. Korngröße: 15 mm  
 Laufrad-Werkstoff: GJL-200 (GG 20)  
 Kennlinien für  $\nu = 1 \text{ mm}^2/\text{s}$

Max. grain size: 15 mm  
 Impeller material: GJL-200 (GG 20)  
 Characteristic lines for  $\nu = 1 \text{ mm}^2/\text{s}$

Tauchpumpe — TGM 50-30/10 250  
 Laufradform —  
 Baugröße —  
 Laufrad-Index —  
 Motorleistung x 10 —  
 Eintauchtiefe in mm —

Submerged pump — TGM 50-30/10 250  
 Form of impeller —  
 Pump size —  
 Impeller-index —  
 Motor power x 10 —  
 Depth of immersion in mm —

Nenn Drehzahl /  
 Nominal rotation speed 2900 min<sup>-1</sup> @ 50 Hz

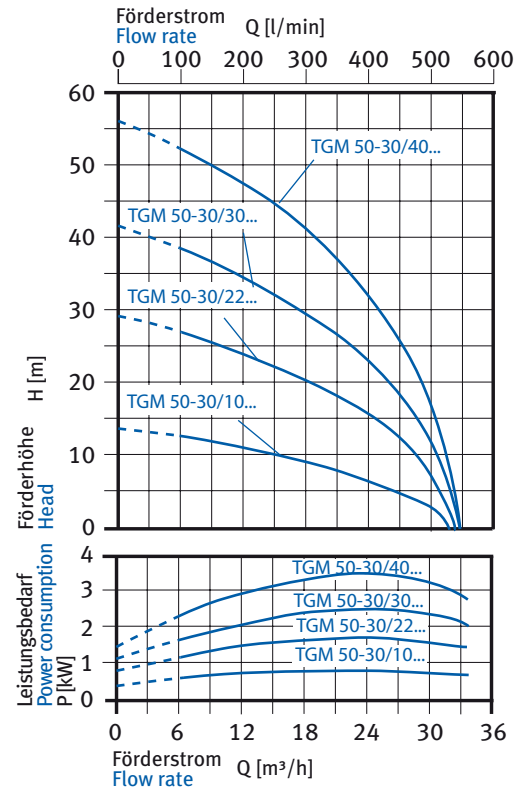

Nenn Drehzahl /  
 Nominal rotation speed 3500 min<sup>-1</sup> @ 60 Hz

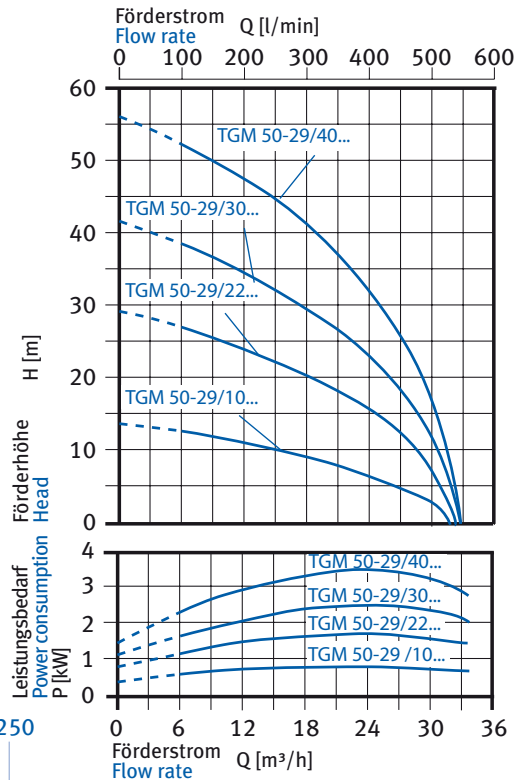

# TGM 50-40

Nennzahl /  
Nominal rotation speed 2900 min<sup>-1</sup> @ 50 Hz

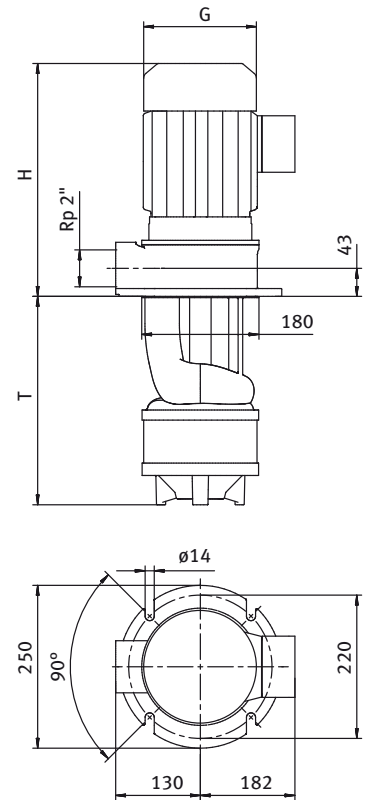
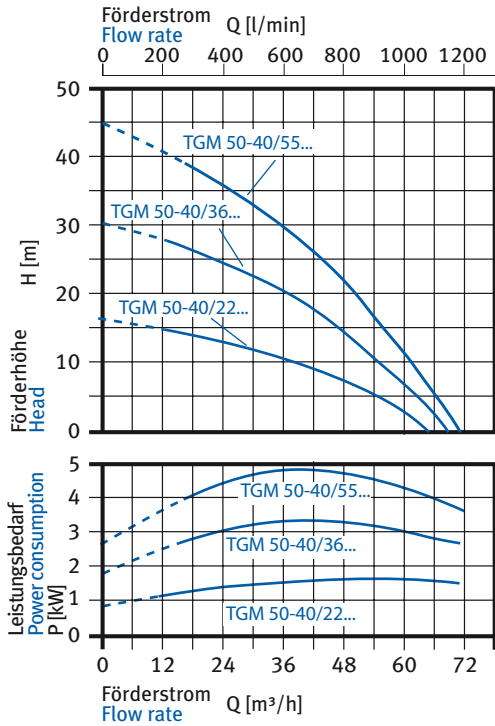

Nennzahl /  
Nominal rotation speed 3500 min<sup>-1</sup> @ 60 Hz

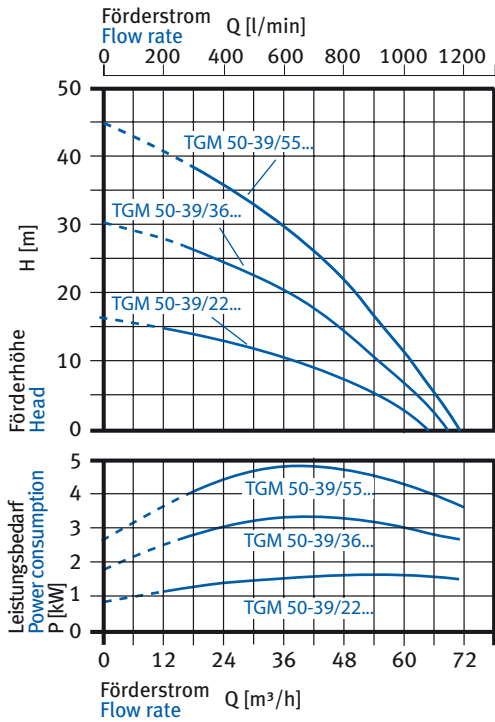

Typ/Type	T (mm)	H (mm)	G (mm)	Gewicht (kg) Weight	Motorleistung (kW) Motor power
TGM 50-.../22 250	250	348	176	36	2,2
TGM 50-.../22 320	320	348	176	38	2,2
TGM 50-.../22 450	450	348	176	39	2,2
TGM 50-.../22 550	550	348	176	40	2,2
TGM 50-.../36 320	320	358	176	46	3,6
TGM 50-.../36 390	390	358	176	48	3,6
TGM 50-.../36 520	520	358	176	50	3,6
TGM 50-.../36 620	620	358	176	52	3,6
TGM 50-.../55 390	390	482	270	54	5,5
TGM 50-.../55 460	460	482	270	56	5,5
TGM 50-.../55 590	590	482	270	58	5,5

Tauchpumpe — TGM 50-40/22 250  
 Laufradform —  
 Baugröße —  
 Laufrad-Index —  
 Motorleistung x 10 —  
 Eintauchtiefe in mm —

Submerged pump — TGM 50-40/22 250  
 Form of impeller —  
 Pump size —  
 Impeller-index —  
 Motor power x 10 —  
 Depth of immersion in mm —

Max. Korngröße: 15 mm  
 Laufrad-Werkstoff: GJL-200 (GG 20)  
 Kennlinien für  $\nu = 1 \text{ mm}^2/\text{s}$

Max. grain size: 15 mm  
 Impeller material: GJL-200 (GG 20)  
 Characteristic lines for  $\nu = 1 \text{ mm}^2/\text{s}$

# TF40

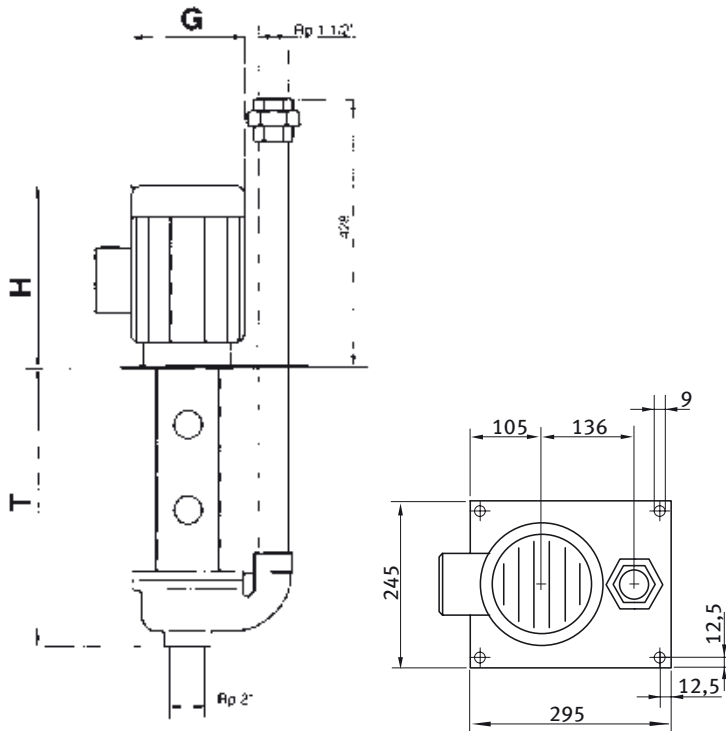

Typ/Type	T (mm)	H (mm)	G (mm)	Gewicht Weight (kg)	Motorleistung Motor power (kW)
TF 40-../07 330	330	270	160	26	0,75
TF 40-../11 330	330	270	160	27	1,1
TF 40-../15 330	330	290	180	30	1,5
TF 40-../22 330	330	320	180	33	2,2
TF 40-../30 330	330	350	200	37	3,0
TF 40-../07 578	578	270	160	33	0,75
TF 40-../11 578	578	270	160	34	1,1
TF 40-../15 578	578	290	180	37	1,5
TF 40-../22 578	578	320	180	40	2,2
TF 40-../30 578	578	350	200	44	3,0
TF 40-../15 826	826	290	180	44	1,5
TF 40-../22 826	826	320	180	47	2,2
TF 40-../30 826	826	350	200	51	3,0

Beispiel: Laufrad-Ø = 115 → TF 40-15/30 330  
 Example: Impeller-Ø = 115 → TF 40-15/30 330

Tauchpumpe — TF 40-15/30 330  
 Laufradform —  
 Baugröße —  
 Laufrad-Index —  
 Motorleistung x 10 —  
 Eintauchtiefe in mm —

Submerged pump — TF 40-15/30 330  
 Form of impeller —  
 Pump size —  
 Impeller-index —  
 Motor power x 10 —  
 Depth of immersion in mm —

## Nenn Drehzahl / Nominal rotation speed 2900 min<sup>-1</sup> @ 50 Hz

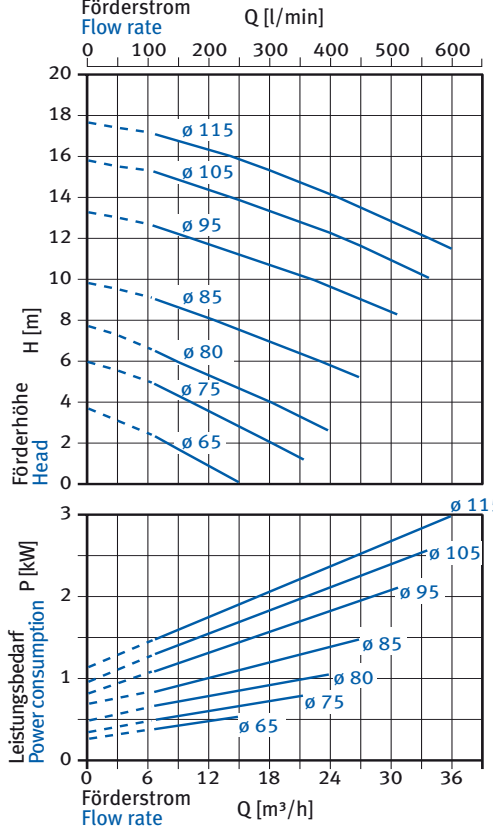

## Nenn Drehzahl / Nominal rotation speed 3500 min<sup>-1</sup> @ 60 Hz

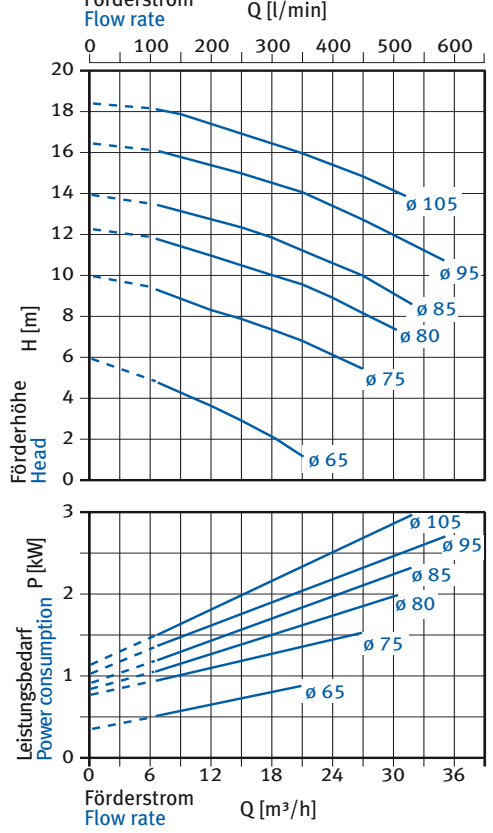

Max. Korngröße: 15 mm  
 Laufrad-Werkstoff: POM/GJL-250 (GG 25)  
 Kennlinien für  $\nu = 1 \text{ mm}^2/\text{s}$   
 Max. grain size: 15 mm  
 Impeller material: POM/GJL-250 (GG 25)  
 Characteristic lines for  $\nu = 1 \text{ mm}^2/\text{s}$



**Nennzahl /**  
**Nominal rotation speed 2900 min<sup>-1</sup> @ 50 Hz**

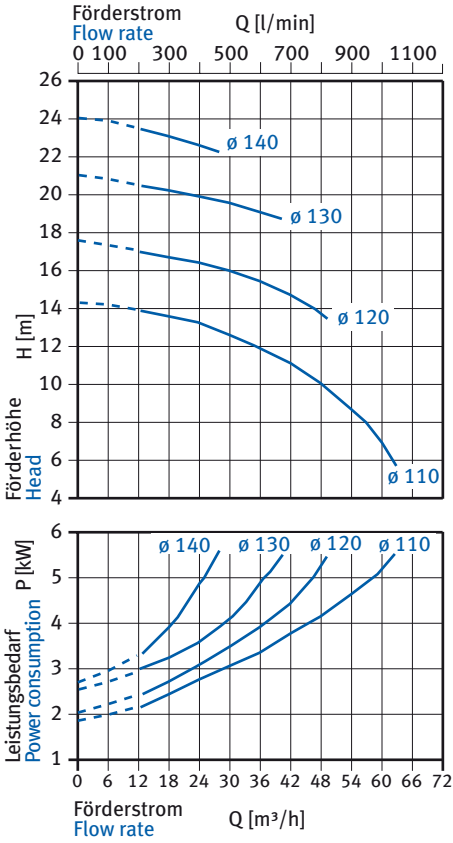

**Nennzahl /**  
**Nominal rotation speed 3500 min<sup>-1</sup> @ 60 Hz**

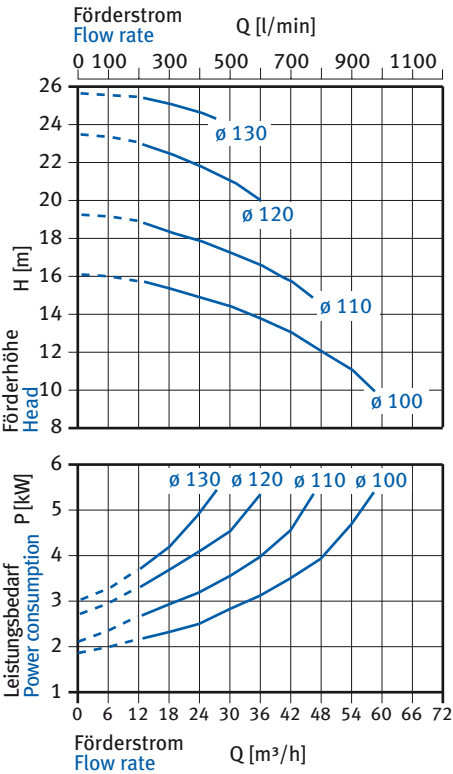

# TF 50

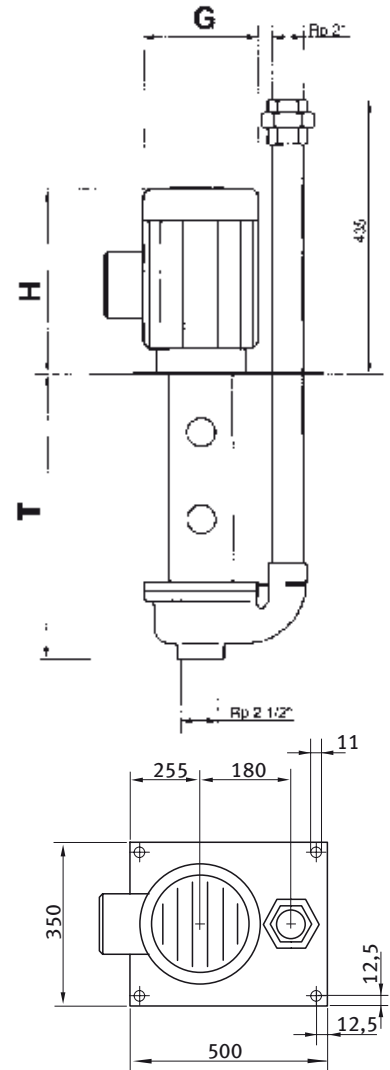

Typ/Type	T (mm)	H (mm)	G (mm)	Gewicht/Weight (kg)	Motorleistung/Motor power (kW)
TF 50-../40 488	488	355	224	68	4,0
TF 50-../55 488	488	355	224	78	5,5
TF 50-../40 848	848	355	224	75	4,0
TF 50-../55 848	848	355	224	85	5,5

Beispiel: Laufrad-Ø = 140 → TF 50-40/55 488

Example: Impeller-Ø = 140 → TF 50-40/55 488

Tauchpumpe — TF 50-40/55 488  
 Laufradform —  
 Baugröße —  
 Laufrad-Index —  
 Motorleistung x 10 —  
 Eintauchtiefe in mm —

Submerged pump — TF 50-40/55 488  
 Form of impeller —  
 Pump size —  
 Impeller-index —  
 Motor power x 10 —  
 Depth of immersion in mm —

Max. Korngröße: 30 mm  
 Laufrad-Werkstoff: GJL-250 (GG 25)  
 Kennlinien für  $\nu = 1 \text{ mm}^2/\text{s}$

Max. grain size: 30 mm  
 Impeller material: GJL-250 (GG 25)  
 Characteristic lines for  $\nu = 1 \text{ mm}^2/\text{s}$

# TS 40

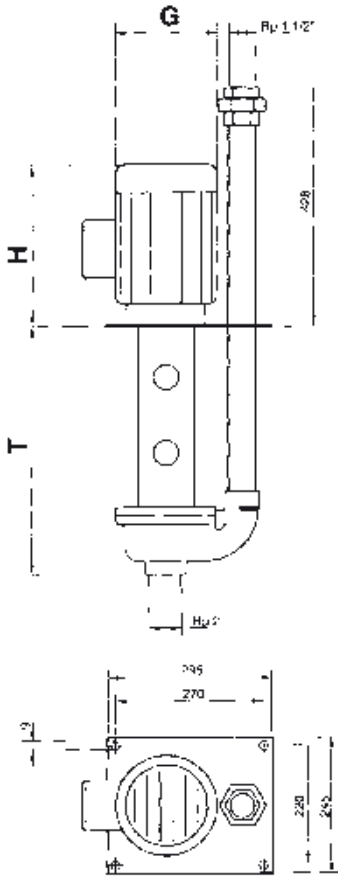

**Nenn Drehzahl /**  
**Nominal rotation speed 2900 min<sup>-1</sup> @ 50 Hz**

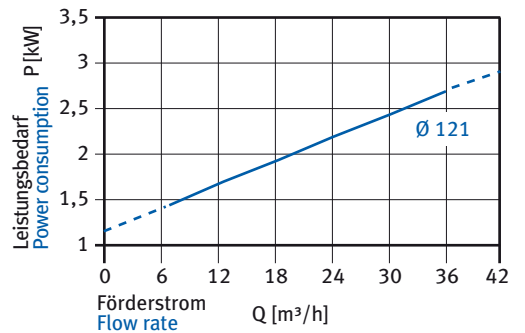
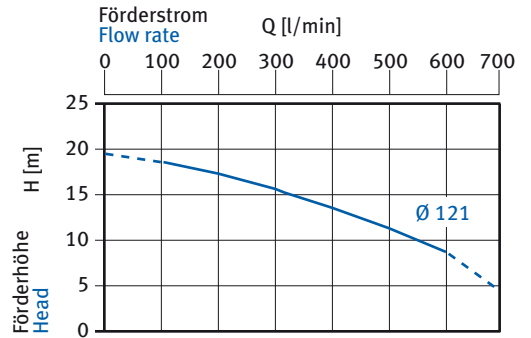

**Nenn Drehzahl /**  
**Nominal rotation speed 3500 min<sup>-1</sup> @ 60 Hz**

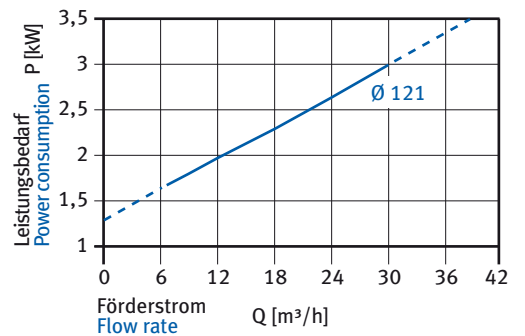
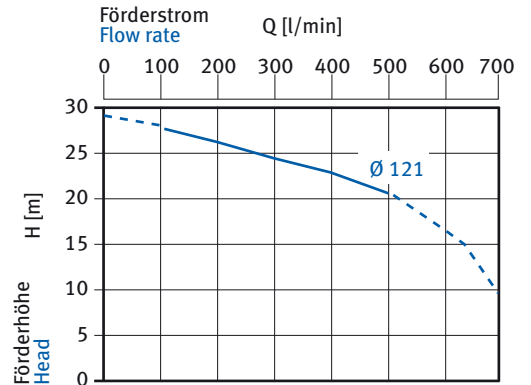

Typ/Type	T (mm)	H (mm)	G (mm)	Gewicht Weight (kg)	Motorleistung Motor power (kW)
TS 40-21/22 338	338	320	180	33	2,2
TS 40-21/30 338	338	350	200	37	3
TS 40-21/22 586	586	320	180	40	2,2
TS 40-21/30 586	586	350	200	44	3
TS 40-21/22 834	834	320	180	47	2,2
TS 40-21/30 834	834	350	200	51	3

Beispiel: Laufrad-Ø = 121 → TS 40-21/30 338

Example: Impeller-Ø = 121 → TS 40-21/30 338

Tauchpumpe — TS 40-21/30 338  
 Laufradform —  
 Baugröße —  
 Laufrad-Index —  
 Motorleistung x 10 —  
 Eintauchtiefe in mm —

Submerged pump — TS 40-21/30 338  
 Form of impeller —  
 Pump size —  
 Impeller-index —  
 Motor power x 10 —  
 Depth of immersion in mm —

Max. Korngröße: 12 mm  
 Laufrad-Werkstoff: ST  
 Kennlinien für  $\nu = 1 \text{ mm}^2/\text{s}$

Max. grain size: 12 mm  
 Impeller material: ST  
 Characteristic lines for  $\nu = 1 \text{ mm}^2/\text{s}$

# TSK 40

Nennzahl /  
Nominal rotation speed  
2900 min<sup>-1</sup> @ 50 Hz

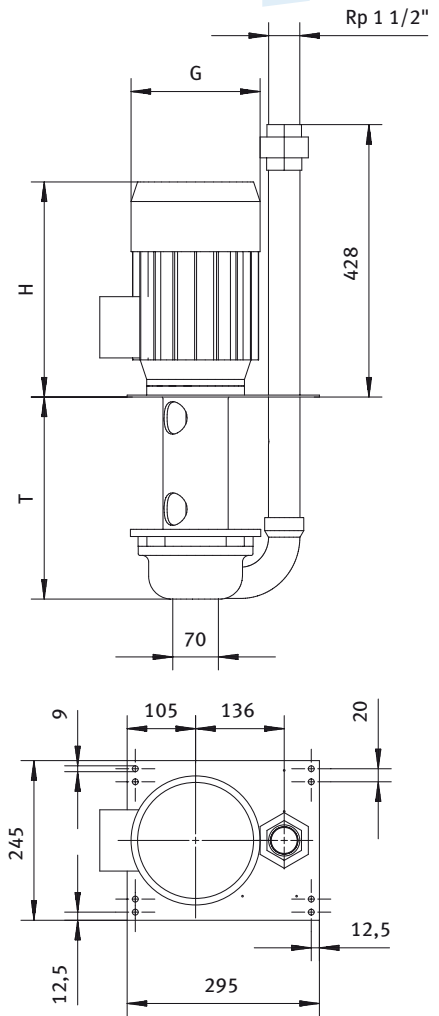
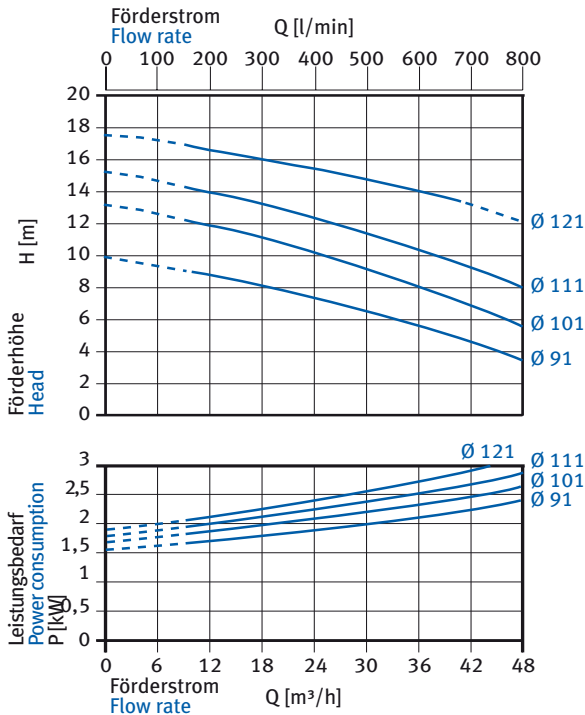

Nennzahl /  
Nominal rotation speed  
3500 min<sup>-1</sup> @ 60 Hz

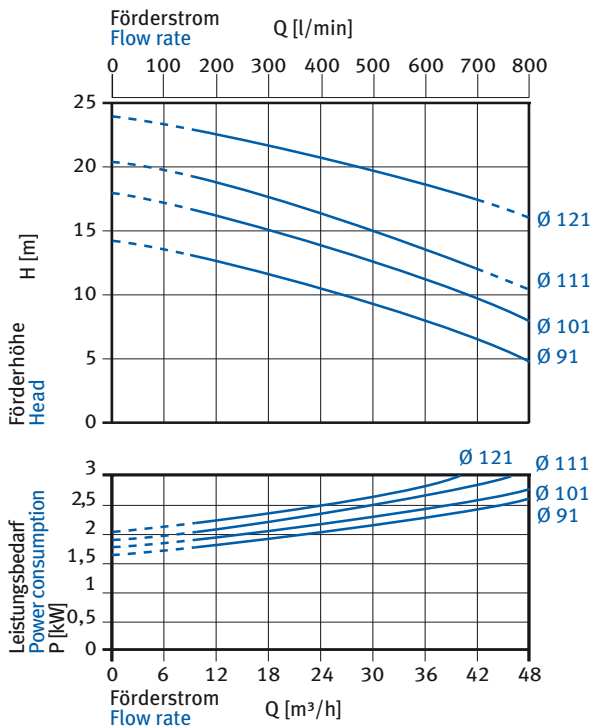

Typ/Type	T (mm)	H (mm)	G (mm)	Gewicht/Weight (kg)	Motorleistung/Motor power (kW)
TSK 40-../22 310	310	320	180	33	2,2
TSK 40-../30 310	310	350	200	37	3
TSK 40-../22 558	558	320	180	40	2,2
TSK 40-../30 558	558	350	200	44	3
TSK 40-../22 806	806	320	180	47	2,2
TSK 40-../30 806	806	350	200	51	3

Tauchpumpe — TSK 40-01/30 310  
 Laufradform —  
 Baugröße —  
 Laufrad-Index —  
 Motorleistung x 10 —  
 Eintauchtiefe in mm —

Submerged pump — TSK 40-01/30 310  
 Form of impeller —  
 Pump size —  
 Impeller-index —  
 Motor power x 10 —  
 Depth of immersion in mm —

Max. Korngröße: 20 mm  
 Laufrad-Werkstoff: ST  
 Kennlinien für  $\nu = 1 \text{ mm}^2/\text{s}$

Max. grain size: 20 mm  
 Impeller material: ST  
 Characteristic lines for  $\nu = 1 \text{ mm}^2/\text{s}$

**KNOLL**  
**.It works**

**KNOLL Maschinenbau GmbH**  
Schwarzachstraße 20  
DE-88348 Bad Saulgau  
Tel. + 49 (0) 75 81/20 08-0  
Fax + 49 (0) 75 81/20 08-140  
info.itworks@knoll-mb.de  
www.knoll-mb.de

# Kreiselpumpen Typ T

## Centrifugal pumps type T

**Atelier certifié pour la réparation des pompes soumises à réglementation ATEX**



**ZAC du Moulin**

**Rue Boucher**

**76410 Cléon - France**

**Téléphone : 02 35 74 48 98**

**Email : [info@eco-tech.pro](mailto:info@eco-tech.pro)**

**[www.eco-tech.fr](http://www.eco-tech.fr)**